

Driver Manual

FS-8700-153 Safe-Fire-Detection – Serial

APPLICABILITY & EFFECTIVITY

Effective for all systems manufactured after June 2023.



Driver Revision: 1.00
Document Revision: 2.B



fieldserver

MSA Safety
1000 Cranberry Woods Drive
Cranberry Township, PA 16066 USA
Website: www.MSAsafety.com

U.S. Support Information:

+1 408 964-4443
+1 800 727-4377
Email: smc-support@msasafety.com

EMEA Support Information:

+31 33 808 0590
Email: smc-support.emea@msasafety.com

Contents

1	Description	4
2	Driver Scope of Supply	4
	2.1 Provided by the Supplier of 3 rd Party Equipment	4
	2.1.1 Hardware.....	4
	2.1.2 Optional Items	4
3	Hardware Connections	5
	3.1 Enable the Gateway Bias and Termination Resistors	6
	3.1.1 FS-QS-2xxx.....	6
	3.1.2 FS-QS-1xxx.....	7
	3.2 Hardware Connection Tips/Hints.....	9
4	Data Array Parameters	10
5	Client Side Configuration	11
	5.1 Client Side Connection Parameters	11
	5.2 Client Side Node Descriptors	12
	5.3 Client Side Map Descriptor Parameters	12
	5.3.1 FieldServer Specific Map Descriptor Parameters	12
	5.3.2 Driver Related Map Descriptor Parameters	12
	5.3.3 Timing Parameters.....	12
	5.4 Map Descriptor Example	13
6	Useful Features	14
	6.1 Data Mapping	14
	6.1.1 Fire-Levels.....	14
	6.1.2 Fault-Status	14
	6.1.3 Air-Flow	15
	6.1.4 Particle-Level and Gain Setting.....	15

1 Description

The Safe-Fire-Detection Master driver implements a data link protocol that uses the services of the RS-485/RS-232 physical layer. CirrusPro network consists of single or multiple detectors and display units. Detector or display unit is referenced as node. Each node is assigned a unique node number. FieldServer will act as master node on network so it should also be configured with a unique node number. This master driver is developed to read current data from each detector node. Data consists of fault status, Fire-Levels, Air Flow value and Particle-Level & gain setting for all 4 pipes.

The information that follows describes how to expand upon the factory defaults provided in the configuration files included with the FieldServer.

Max Nodes Supported

FieldServer Mode	Nodes	Comments
Client	32	
Server	N/A	

2 Driver Scope of Supply

2.1 Provided by the Supplier of 3rd Party Equipment

2.1.1 Hardware

Description
CirrusPro Series detectors on RS-485/RS-232 Network

2.1.2 Optional Items

Part #	Vendor/Manufacturer	Description
FS-4301-00	FieldServer	RS-232 to RS-485 converter

3 Hardware Connections

Configure the Safe-Fire-Detection network according to manufacturer's instructions.

Enable BIAS and termination registers on FieldServer.

The FieldServer is connected to the Safe-Fire network as shown in connection drawing below.

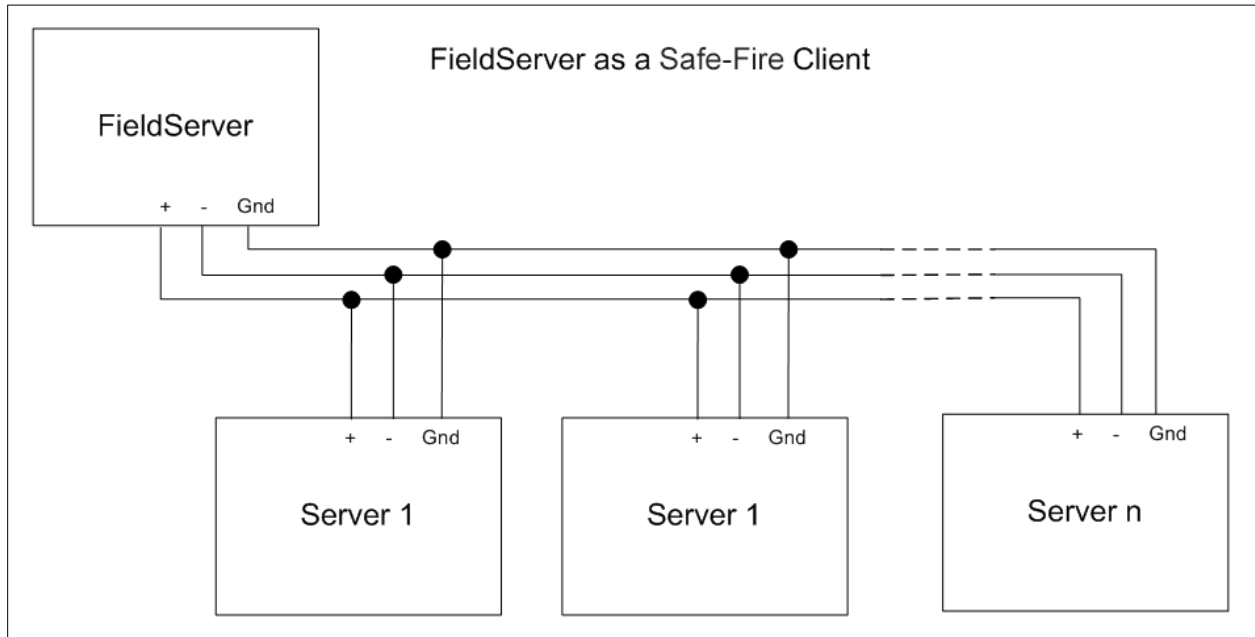

3.1 Enable the Gateway Bias and Termination Resistors

The gateway Bias and Termination Resistors must be enabled to allow the gateway to communicate with the Safe Fire panel.

3.1.1 FS-QS-2xxx

See the image for the orientation of switch positions referenced below. Both BIAS- and BIAS+ must be enabled.

- The default factory setting is in the OFF position (switch is to the **left** side as shown below).
- To enable, move the switches to the ON position (switch is on the **right** side)

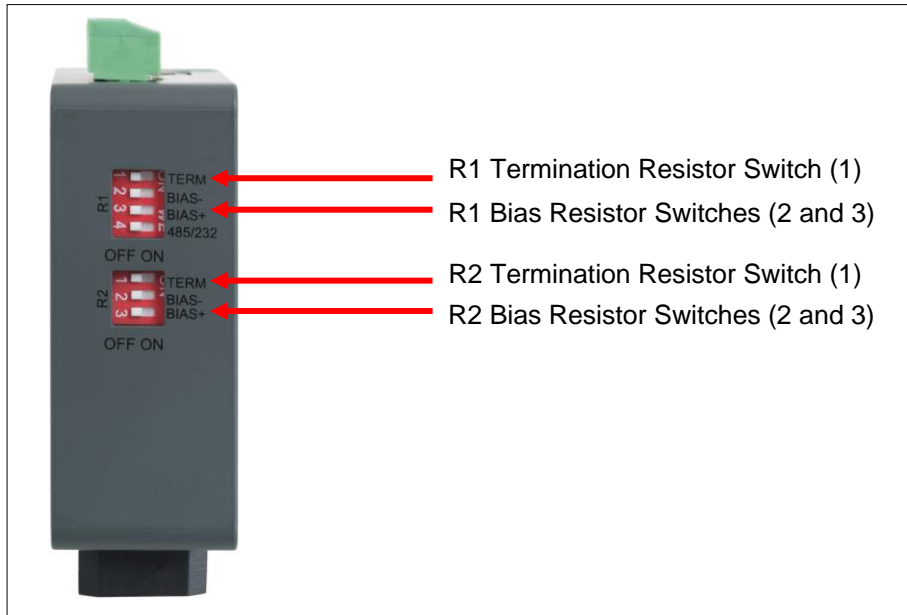

NOTE: The image shows all switches in the OFF position.

3.1.2 FS-QS-1xxx

Connecting the Safe Fire Panel to the 3-Pin Port

Remove the purple cover to expose the small DIP switches near the field port (opposite of the 6-pin port).

See the image for the orientation of switch positions referenced below.

- The default factory setting is in the OFF position (switch is to the **right** side as shown below).
- To enable, move the switches to the ON position (switch is on the **left** side).

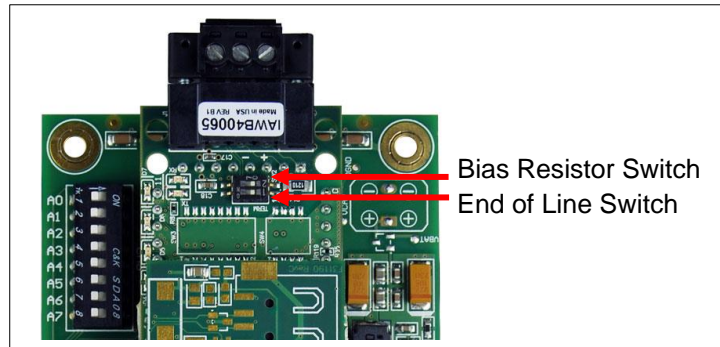

NOTE: The image shows both switches in the OFF position.

Connecting the Safe Fire Panel to the 6-Pin Port

- The default positions from the factory for the biasing jumpers are OFF.
- The OFF position is when the 2 red biasing jumpers straddle the 4 pins closest to the outside of the board.
- To turn biasing ON, move the 2 red biasing jumpers to straddle the 4 pins closest to the inside of the board of the ProtoNode.

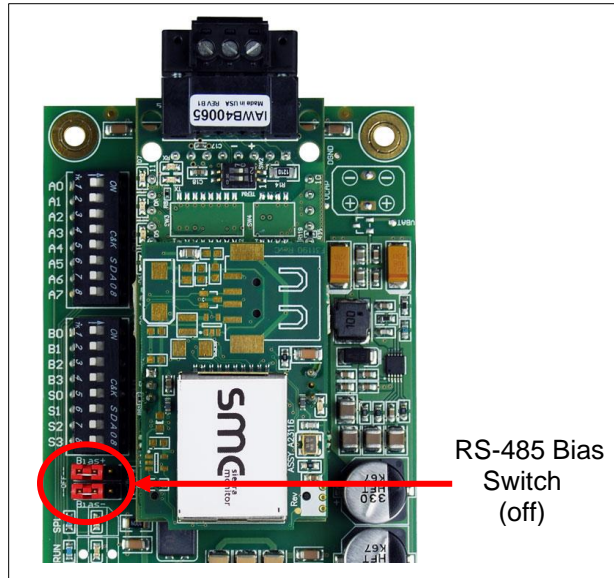

- The default position from the factory for the end of line (EOL) switch is OFF.
- The OFF position is when the blue jumper is straddling the pins closest to the inside of the board.
- To turn the EOL switch ON, move the blue switch straddling the pins closest to the outside of the board.

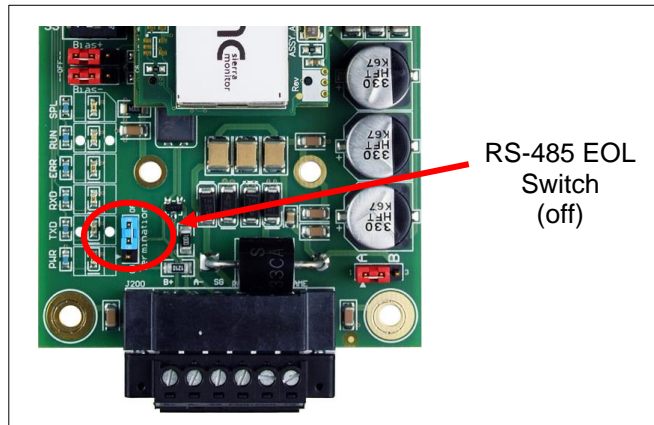

3.2 Hardware Connection Tips/Hints

Follow standard RS-485 2-wire guidelines for installation. See connection diagram below.

Also enable BIAS register on FieldServer.

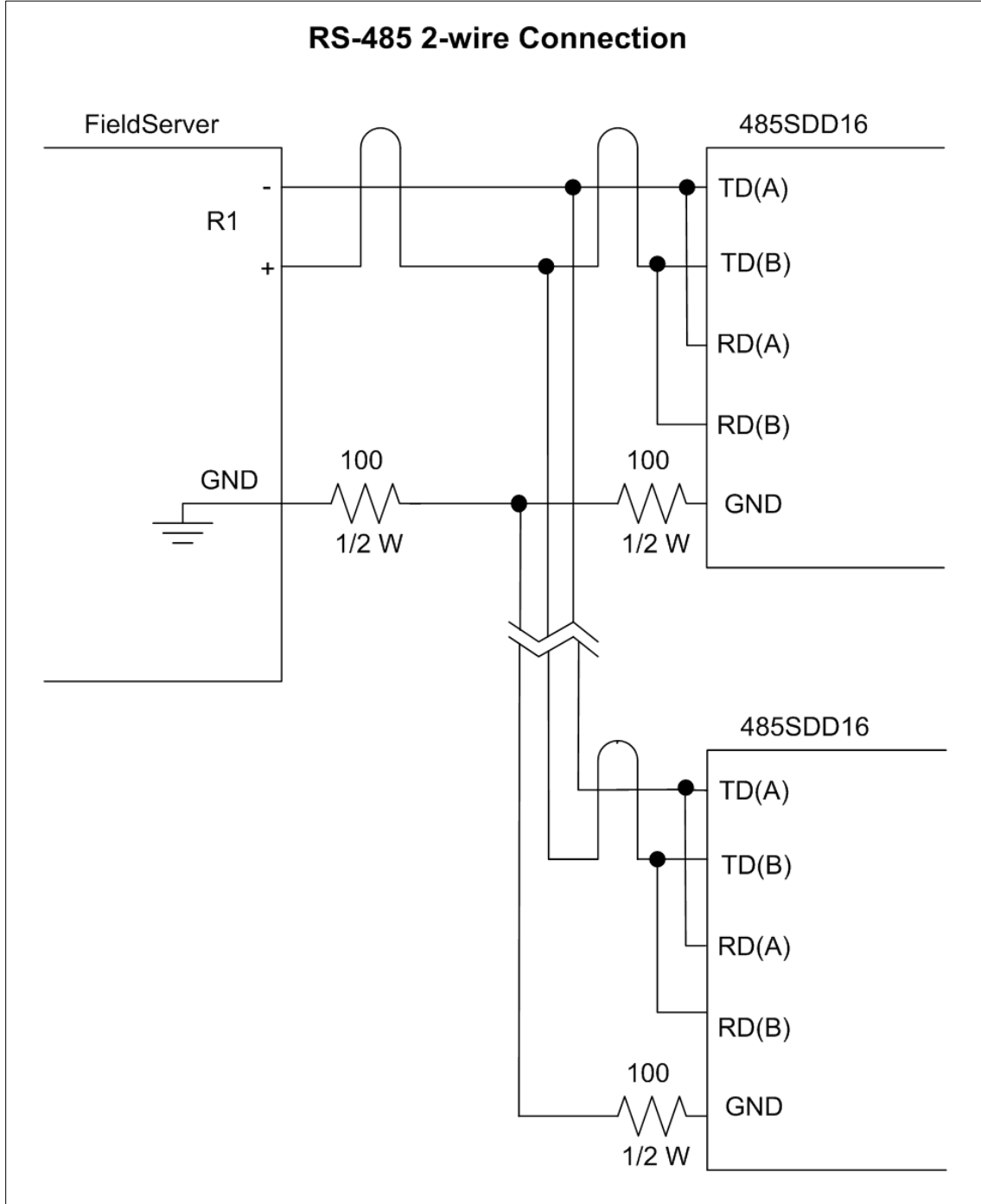

4 Data Array Parameters

Data Arrays are “protocol neutral” data buffers for storage of data to be passed between protocols. It is necessary to declare the data format of each of the Data Arrays to facilitate correct storage of the relevant data.

Section Title		
Data_Arrays		
Column Title	Function	Legal Values
Data_Array_Name	Provide name for Data Array.	Up to 15 alphanumeric characters
Data_Array_Format	Provide data format. Each Data Array can only take on one format.	Float, Bit, Byte, Uint16, Uint32, Sint16, Sint32
Data_Array_Length	Number of Data Objects. Must be larger than the data storage area required by the Map Descriptors for the data being placed in this array.	1-10000

Example

```
// Data Arrays
Data_Arrays
Data_Array_Name , Data_Format , Data_Array_Length
DA_Fire_Levels , Bit , 16
DA_Fault_Status , Bit , 32
DA_Air_Flow , Uint16 , 4
DA_PLevels_Gain , Uint16 , 8
```

5 Client Side Configuration

For detailed information on FieldServer configuration, refer to the FieldServer Configuration Manual. The information that follows describes how to expand upon the factory defaults provided in the configuration files included with the FieldServer (see “.csv” sample files provided with the FieldServer).

This section documents and describes the parameters necessary for configuring the FieldServer to communicate with a Safe-Fire Server.

The configuration file tells the FieldServer about its interfaces, and the routing of data required. In order to enable the FieldServer for Safe-Fire communications the following three actions must be taken. The driver independent FieldServer buffers need to be declared in the “Data Arrays” section. The destination device addresses need to be declared in the “Client Side Nodes” section. And the data required from the server(s) needs to be mapped in the “Client Side Map Descriptors” section. Details on how to perform these steps can be found in the following sections.

NOTE: In the tables below, * indicates an optional parameter, with the bold legal value as default.

5.1 Client Side Connection Parameters

Section Title		
Connections		
Column Title	Function	Legal Values
Port	Specify which port the device is connected to the FieldServer.	P1-P2, R1-R2 ¹
Baud*	Specify baud rate.	19200
Parity*	Specify parity.	None
Data_Bits*	Specify data bits.	8
Stop_Bits*	Specify stop bits.	2
Protocol	Specify protocol used.	Safe-Fire
Poll Delay*	Time between internal polls.	0-65.534s, 0.1s
Timeout*	Maximum time to wait for response from server.	0-65.534s, 5s
Safe_Fire_Node_Number*	Assign a unique Safe-Fire node number to FieldServer.	0-255, 127

Example

```
// Client Side Connections
Connections
Port , Baud , Parity , Data_Bits , Stop_Bits , Protocol , Poll_Delay , Timeout
R1 , 19200 , None , 8 , 2 , Safe-Fire , 0.100s , 5s
```

¹ Not all ports shown may be supported by the hardware. Consult the appropriate Instruction manual for details of the hardware.

5.2 Client Side Node Descriptors

Section Title		
Nodes		
Column Title	Function	Legal Values
Node_Name	Provide name for node.	Up to 32 alphanumeric characters
Node_ID	Specify the remote Safe-Fire node number.	1 – 255
Protocol	Specify protocol used.	Safe-Fire
Port	Specify port.	R1-R2

Example

```
// Client Side Nodes
Nodes
Node_Name , Node_ID , Protocol , Port
Det_255 , 255 , Safe-Fire , R1
Node_Name , Node_ID , Protocol , Port
```

5.3 Client Side Map Descriptor Parameters

5.3.1 FieldServer Specific Map Descriptor Parameters

Column Title	Function	Legal Values
Map_Descriptor_Name	Name of this Map Descriptor.	Up to 32 alphanumeric characters
Data_Array_Name	Name of Data Array where data is to be stored in the FieldServer.	One of the Data Array names from “Data Array” section above
Data_Array_Offset	Starting location in Data Array.	0 to maximum specified in “Data Array” section above
Function	Function of Server Map Descriptor.	RDBC

5.3.2 Driver Related Map Descriptor Parameters

Column Title	Function	Legal Values	
Node_Name	Name of Node to fetch data from.	One of the Node names specified in Node Descriptor section	
Safe_Fire_Request	Specify the safe-fire request type.	Safe-Fire-Levels, Fault-Status, Air-Flow, Particle-Level	
Length	Specify the number of data array locations used to store the data of the specified Safe_Fire_Request.	Safe-Fire-Request	Length
		Safe-Fire-Levels	16
		Fault-Status	32
		Air-Flow	4
		Particle-Level	8

5.3.3 Timing Parameters

Column Title	Function	Legal Values
Scan_Interval*	Rate at which data is polled.	0-65535s, 2s

5.4 Map Descriptor Example

Following examples below are to read all the required data from Detector_255.

See **Section 6.1** for details on data mapping.

Map_Descriptors	Map_Descriptor_Name	Data_Array_Name	Data_Array_Offset	Function	Node_Name	Safe_Fire_Request	Length	Scan_Interval
	CMD_Fire_Levels	DA_Fire_Levels	0	Rdbc	Det_255	Fire-Levels	16	1.000s
	CMD_Fault_Status	DA_Fault_Status	0	Rdbc	Det_255	Fault-Status	32	1.000s
	CMD_Fire_Levels	DA_Fire_Levels	0	Rdbc	Det_255	Air-Flow	4	1.000s
	CMD_Fire_Levels	DA_Fire_Levels	0	Rdbc	Det_255	Particle-Level	8	1.000s

6 Useful Features

6.1 Data Mapping

6.1.1 Fire-Levels

Data Array Offset	Data Description
0	Pipe1 Pre-Alarm
1	Pipe1 Fire1
2	Pipe1 Fire2
3	Pipe1 Fire3
4	Pipe2 Pre-Alarm
5	Pipe2 Fire1
6	Pipe2 Fire2
7	Pipe2 Fire3
8	Pipe3 Pre-Alarm
9	Pipe3 Fire1
10	Pipe3 Fire2
11	Pipe3 Fire3
12	Pipe4 Pre-Alarm
13	Pipe4 Fire1
14	Pipe4 Fire2
15	Pipe4 Fire3

6.1.2 Fault-Status

Data Array Offset	Data Description (0/1)
0	Processor Fault
1	EEPROM Corrupt
2	Supply Fault
3	No Water Fault
4	Chamber Seal Fault
5	Chamber Vacuum Fault
6	Chamber LED Fault
7	Water Fill Fault
8	Air Flow Fault
9	Stack Overflow Fault
10	Unit Isolated
11	Low Supply
12	High AlgoTech Background
13	Unit Too Cold
14	Unit Disabled
15	Expansion PCB Fault
16	External Fault
17	Battery Fault
18	Sample Block Fault
19	Purge Blockage Fault
20	Chamber Seal Fault
21	Pipe Scan Disabled
22-31	For Future Use

6.1.3 Air-Flow

Data Array Offset	Data Description (%)
0	Pipe1 Air Flow
1	Pipe2 Air Flow
2	Pipe3 Air Flow
3	Pipe4 Air Flow

6.1.4 Particle-Level and Gain Setting

Data Array Offset	Data Description
Particle-Level (%)	
0	Pipe1 Particle Level
1	Pipe1 Particle Level
2	Pipe1 Particle Level
3	Pipe1 Particle Level
Gain Setting (1-10)	
4	Pipe1 Gain Setting
5	Pipe2 Gain Setting
6	Pipe3 Gain Setting
7	Pipe4 Gain Setting