

Driver Manual

FS-8700-150 M-Bus

APPLICABILITY & EFFECTIVITY

Effective for all systems manufactured after February 2024.



Driver Revision: 1.08
Document Revision: 3.C



fieldserver

MSA Safety
1000 Cranberry Woods Drive
Cranberry Township, PA 16066 USA
Website: www.MSAsafety.com

U.S. Support Information:
+1 408 964-4443
+1 800 727-4377
Email: smc-support@msasafety.com

EMEA Support Information:
+31 33 808 0590
Email: smc-support.emea@msasafety.com

Contents

1	Description	4
2	Driver Scope of Supply	4
2.1	Required 3 rd Party Equipment.....	4
3	Hardware Connections	5
3.1	Power Supply Requirement.....	5
3.2	Connection Diagrams.....	5
3.3	M-Bus Wiring Guidelines.....	6
3.3.1	Network Topology.....	6
3.3.2	M-Bus Cable.....	7
3.3.3	Theoretical Maximum Cable Length in M-Bus Networks.....	8
3.4	Jumper Settings.....	9
3.4.1	M-Bus Master.....	9
3.4.2	M-Bus Slave.....	9
4	Data Array Parameters	10
5	Master Side Configuration	11
5.1	Master Side Connection Parameters.....	11
5.2	Master Side Node Parameters.....	12
5.3	Master Side Map Descriptor Parameters.....	13
5.3.1	FieldServer Specific Map Descriptor Parameters.....	13
5.3.2	All data Request Driver Related Map Descriptor Parameters.....	13
5.3.3	Specific Data Request Driver Related Map Descriptor Parameters.....	13
5.4	Map Descriptor Examples.....	14
6	Slave Side Configuration	15
6.1	Slave Side Connection Parameters.....	15
6.2	Slave Side Node Parameters.....	16
6.3	Server Side Map Descriptor Parameters.....	17
6.3.1	FieldServer Specific Map Descriptor Parameters.....	17
6.3.2	Driver Related Map Descriptor Parameters.....	17
6.3.3	Specific Data Request Driver Related Map Descriptor Parameters.....	17
6.4	Map Descriptor Example.....	18
7	Troubleshooting	19
7.1	Driver Error Messages.....	19
7.2	Short Circuit LED.....	21
8	Reference	22
8.1	M-Bus Data Types.....	22
8.2	Auto Baud Discovery.....	23
8.3	Device Profile Listings.....	23
8.4	VIF Table.....	24

1 Description

The M-Bus driver allows the FieldServer to transfer data to and from devices using M-Bus protocol. The fieldbus connection is included with the FieldServer. The FieldServer can emulate either a Slave or a Master.

The M-Bus QuickServer Gateway is configurable to act as both a Master and a Slave M-Bus device. As an M-Bus Master the number of devices supported is limited to 64 devices since the FieldServer provides power to the M-Bus. The M-Bus Master interrogates the Slave devices as the gateway acts as a Master. It will request information from the Slave devices and receive and process only the expected responses. As an M-Bus Slave the maximum number of devices is limited to the M-Bus standard of 250. The Gateway will act as a Slave and will respond only to requests from M-Bus Master devices.

Max Nodes Supported

FieldServer Mode	Max Nodes	Comments
M-Bus Master Mode	64	Maximum number of Slave Nodes supported by FieldServer.
M-Bus Master Mode	1	Maximum number of Master Nodes represented by FieldServer.
M-Bus Slave Mode	1	Only one Master on the M-Bus network.
M-Bus Slave Mode	250	Maximum number of Slave Nodes represented by FieldServer.

NOTE: Emulation of local Master and Slave nodes is not possible as the Master and Slave hardware is not interchangeable.

NOTE: If the bridge is set as an M-Bus Slave, Auto Discovery is not supported if multiple virtual nodes are configured.

2 Driver Scope of Supply

2.1 Required 3rd Party Equipment

Refer to M-Bus wiring specifications for required equipment.

3 Hardware Connections

3.1 Power Supply Requirement

A power supply rated 15 W or more is recommended to support 64-Slave devices when the FieldServer is configured as a Master device.

3.2 Connection Diagrams

- The FieldServer can be either a Master or a Slave device. See **Section 3.4** for jumper settings to select the correct hardware setting.
- Most M-Bus devices are not polarity sensitive, although the diagram shows the polarity, should it be a requirement.
- Configure the M-Bus devices according to the manufacturer's instructions (e.g. primary address and readout data).

NOTE: The M-Bus QuickServer does not need a level converter.

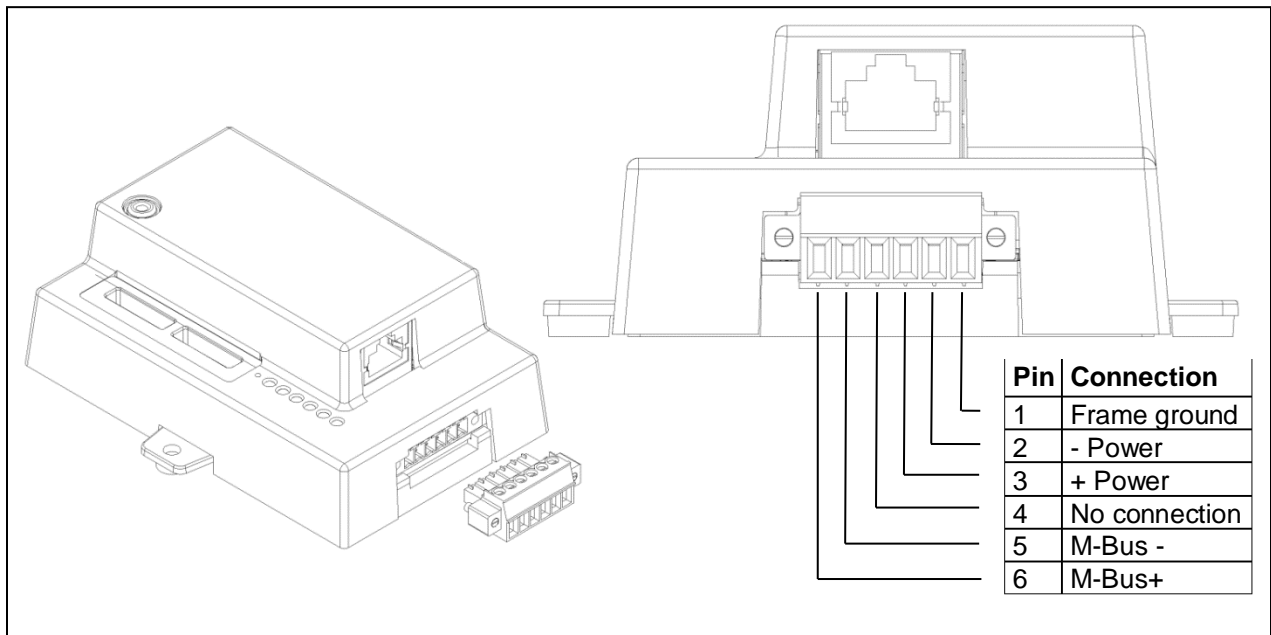

NOTE: When designing an M-Bus network, only one M-Bus Master can be used with multiple M-Bus Slave devices. Connecting more than one M-Bus Master to the same network could result in the permanent damage to the M-Bus Masters' hardware.

3.3 M-Bus Wiring Guidelines

3.3.1 Network Topology

The topology of the M-Bus network is (almost) arbitrary. Only the ring topology as shown beneath should be avoided. In general, the length of the cables should be minimized.

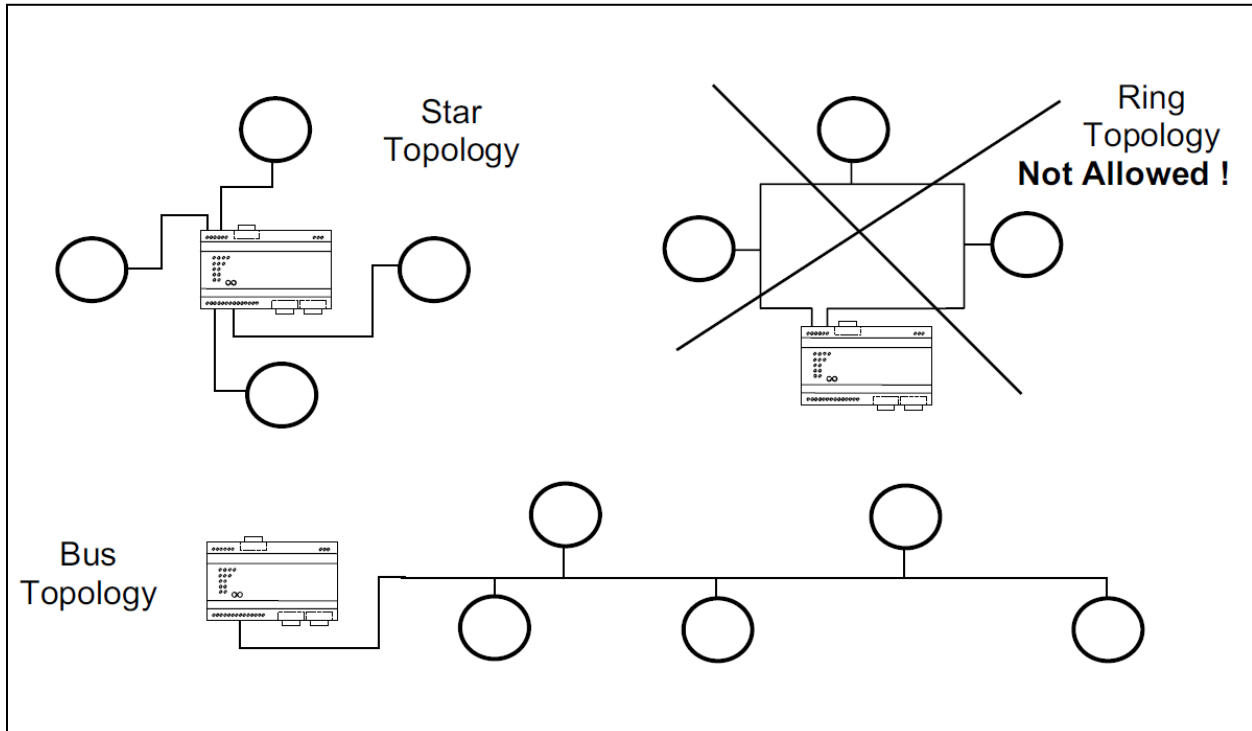

Usually a mixture between star and bus topology should be used.

3.3.2 M-Bus Cable

The M-Bus uses two wire cables which are going from the M-Bus Master / Repeater to each M-Bus device (bus structure). The M-Bus is **polarity independent** and needs no line termination resistors at the end of the cables.

Any cable type may be used as long as the cable is suitable for 42 V / 500 mA. Shielding is not necessary and not recommended since the capacity of the cable should be minimized.

In most cases a standard telephone cable is used which is a twisted pair wire with a diameter of 0.8 mm each (2 x 0.8 mm). This type of cable should be used for the main wiring. For the wiring to the meters from the main wiring (last 1 ... 5 m to the meter) a cable with smaller diameter may be used.

The maximum distance between a slave and the repeater is 350 m. This distance applies for the standard configuration having Baud rates between 300 and 2400 Baud, and a maximum of 250 slaves. The maximum distance can be increased by limiting the Baud rate and using fewer slaves (see below theoretical calculations and the table below), but the bus voltage at no point in a segment fall below 24V, because of the remote powering of the slaves. In the standard configuration, the total cable length should not exceed 1000 m, in order to meet the requirement of a maximum cable capacitance of 180 nF.

NOTE: In normal installations, the cable length should be limited to 1000m. If baud rate is set to 9600 the distances will be significantly shorter.

Recommended M-Bus Cable (Telephone Cable)	
Cable Type	2 x 0.8 mm (JYStY N*2*0.8 mm)
Cable Resistance	75 Ohm / km
Cable Capacity	50 nF / km

Table Characteristics for Typical CAT5e (ANSI/TIA/EIA-568-A)	
Cable Type	CAT5e Solid Copper Wire AWG24
Max Cable Current per Conductor	0.577 Amp
Cable Resistance	<188 Ohm / km
Cable Capacity	52 nF / km

Although it is possible to use CAT5e UTP cable, this will shorten the maximum allowed cable distances due to higher resistance. For max. of 60 M-bus devices the max segment resistance is 175 kOhms, therefore the maximum theoretical distance using CAT5e would be around 930 meters. In practice using CAT5 cable it is practical to limit the segment length to maximum of 305m for up to 60 devices due to differences in CAT5 cable electrical characteristics. This is the total cable length including spurs etc.

3.3.3 Theoretical Maximum Cable Length in M-Bus Networks

The question for the maximum possible cable length in M-Bus networks is not easy to answer since several parameters are critical. However, an example calculation is shown here to give an estimation.

Cable and Capacity Information	
Cable Type	2 x 0.8 mm (JYStY N*2*0.8 mm)
Cable Resistance	75 Ohm / km
Cable Capacity	50 nF / km
Capacity of one M-Bus Device	1 nF
Current of one M-Bus Device	1.5 mA

The limiting parameters in M-Bus networks are mainly the cable resistance and the cable capacity plus the capacity of the devices (= bus capacity).

The cable resistance causes, depending on the bus current, a bus voltage drop. The maximum bus voltage drop may not be more than 16 V ... 18 V since the minimum bus voltage at any device must not be lower than 24 V (40 V – 24 V = 16 V).

$$R = U / I$$

$$U_{max} = 16V$$

$$I = N * 1.5mA$$

$$R = 16 / (1.5 * N) \text{ Ohm}$$

where

R = Cable Resistance

U = Voltage Drop over Cable Length

I = Bus Current

N = Number of Connected M-Bus Devices

The cable resistance, therefore, limits the maximum possible cable length from the M-Bus Master / Repeater to the device with the largest distance away from it (largest cable segment). The table beneath shows theoretical maximum cable segment lengths:

Number of M-Bus Devices	Max Segment Resistance	Max Cable Segment Length (75kOhm / km)
1	10.7 kOhm	142 km
10	1.1 kOhm	14.7 km
50	213 Ohm	2.8 km
100	106 Ohm	1.4km
150	71 Ohm	0.95 km
200	53 Ohm	0.71 km
250	43 Ohm	0.57 km

NOTE: The given maximum cable segment length takes into account only the bus resistance and not the bus capacity. Therefore, some of the cable lengths in the table may not be possible in reality. At the end of the chapter is a table with real example configurations.

NOTE: The M-bus segments can be extended using M-MEX10/MEX11/MEX12 M-Bus Extender Modules.

The cable capacity plus the capacity of the M-Bus devices (= bus capacity) is responsible for sloppy signal edges. Therefore, the bus capacity limits the maximum data transfer rate of the M-Bus. The table beneath gives an estimation of the bus capacity / baud rate relationship.

Baud Rate	Max Bus Capacity	Example Configuration
2400	300 nF	50 Devices + 5km Cable ($50 * 1\text{nF} + 5\text{km} * 50\text{nF}$) 250 Devices + 1km Cable ($250 * 1\text{nF} + 1\text{km} * 50\text{nF}$)
9600	100 nF	1 Device + 2 km Cable ($1 * 1\text{nF} + 2\text{km} * 50\text{nF}$) 50 Devices + 1km Cable ($50 * 1\text{nF} + 1\text{km} * 50\text{nF}$) 80 Devices + 400m Cable ($80 * 1\text{nF} + 0.4\text{km} * 50\text{nF}$)

NOTE: The mentioned example configurations are taking into account only the bus capacity but not the bus resistance. Therefore, some of the cable lengths in the table may not be possible in reality.

3.4 Jumper Settings

Please ensure that the power supply to the M-Bus connection and the Power connection is switched OFF or unplugged before changing jumper settings.

3.4.1 M-Bus Master

Set the two jumpers (oriented in a horizontal position) to the left side marked as “Master” as shown in the figure.

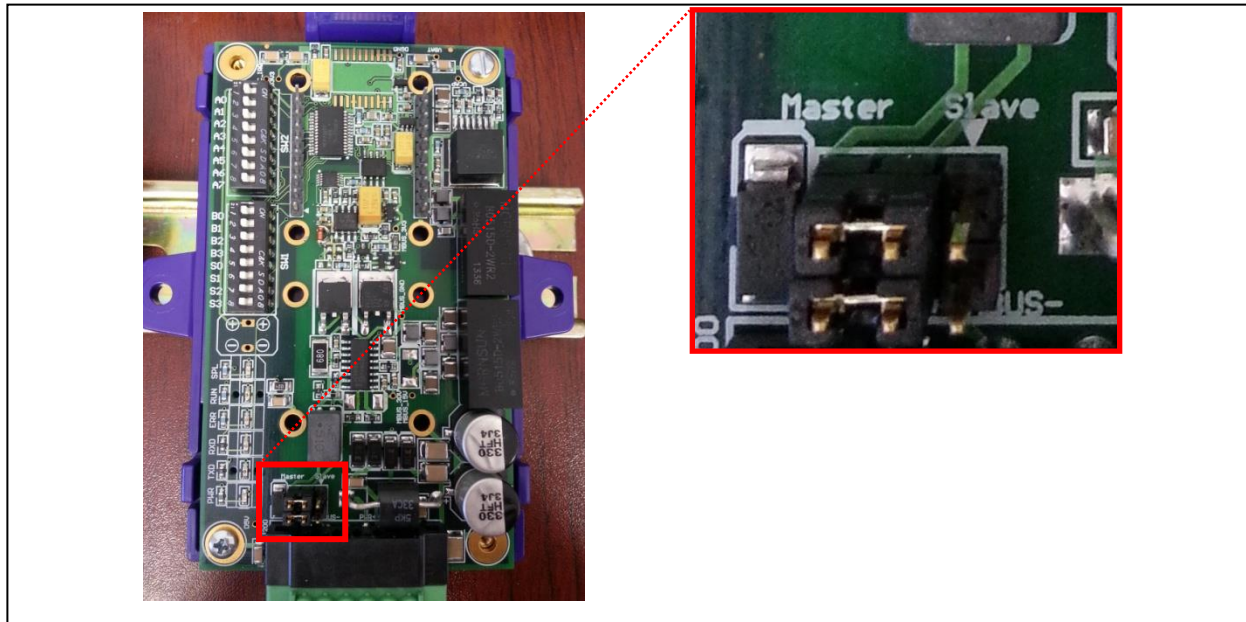

3.4.2 M-Bus Slave

Set the two jumpers (oriented in a horizontal position) to the side marked as “Slave”. See the board image in **Section 3.4.1** for reference.

4 Data Array Parameters

Data Arrays are “protocol neutral” data buffers for storage of data to be passed between protocols. It is necessary to declare the data format of each of the Data Arrays to facilitate correct storage of the relevant data.

Section Title		
Data_Arrays		
Column Title	Function	Legal Values
Data_Array_Name	Provide name for Data Array.	Up to 15 alphanumeric characters
Data_Array_Format	Provide data format. Each Data Array can only take on one format.	Float, Bit, Byte, Uint16, Uint32, Sint16, Sint32
Data_Array_Length	Number of Data Objects. Must be larger than data area required by the Map Descriptors for data stored in this array.	1-10000

Supported Data Point Types

M-bus data is divided into two classes: Class-1 alarm protocol (higher priority) and Class-2 general data protocol. Class-1 alarm data is available according to the Slave vendor specific format and is stored accordingly. Custom data types specified in the VIF, DIF, and DIFE are supported.

In master mode, the driver can read a slave's data points, and any ASCII meta data that is sent with the point can be displayed. In slave mode, the driver will serve the point as a custom point, but specifying an ASCII description is not supported. (The master will only see it as a custom data type with no description.)

This table lists Class 2 general data types and the FieldServer Data Array type used to store data.

Class-2 Data Type	Description	Recommended Data Array Types
Duration types	Time duration in seconds, minutes, hours and days	FLOAT
Energy types	Energy consumption, usually for billing purposes (Watt hour/Joules)	FLOAT
Voltage	Voltage reading of a meter	FLOAT
Current	Current reading of a meter	FLOAT
Temperature types	Temperature reading (°C or °F)	FLOAT
Time types	Time in seconds, minutes, hours and days	FLOAT
Custom types	Custom value, where the data type is specified in the VIF	FLOAT
Power types	Power reading (Watts or Joules/s)	FLOAT
Pressure	Pressure reading in bar.	FLOAT
Mass	Mass scaled value (kg)	FLOAT
Mass flow	Mass flow scaled value (kg/h)	FLOAT
Volume flow types	Volume flow value in litre per minute	FLOAT
Volume type	Volume value in cubic meters	FLOAT
Alarm flags	Volume flow value in litre per second	BYTE
Device ID	The device's ID/Serial number	UINT32
Medium	The device's measuring medium	BYTE
Unknown	Any remaining data types are stored	UINT32

Example

```
// Data Arrays
Data_Arrays
Data_Array_Name , Data_Array_Format , Data_Array_Length
DA_MBUS_01 , Uint32 , 50
DA_MBUS_02 , BYTE , 50
DA_MBUS_03 , FLOAT , 50
```

5 Master Side Configuration

For a detailed discussion on FieldServer configuration, please refer to the FieldServer Configuration Manual. The information that follows describes how to expand upon the factory defaults provided in the configuration files included with the FieldServer (see “.csv” sample files provided with the FieldServer).

This section documents and describes the parameters necessary for configuring the FieldServer as an M-Bus Master to communicate with an M-Bus Slave device.

The configuration file tells the FieldServer about its interfaces, and the routing of data required. In order to enable the FieldServer for M-Bus communications, the driver independent FieldServer buffers need to be declared in the “Data Arrays” section, the destination device addresses need to be declared in the “Master Side Nodes” section, and the data required from the Slaves needs to be mapped in the “Master Side Map Descriptors” section. Details on how to do this can be found below.

NOTE: In the tables below, * indicates an optional parameter, the bold legal value is the default.

5.1 Master Side Connection Parameters

Section Title		
Connections		
Column Title	Function	Legal Values
Port	Specify which port the device is connected to the FieldServer.	R1-R2
Protocol	Specify protocol used.	MBUS
Baud*	Desired Baud Rate to use for the M-Bus Network. See Section 8.2 for “Auto Baud Discovery”.	300, 600, 1200, 2400 , 4800, 9600, 19200, 38400
Auto_Baud_Discovery*	Enables/Disables the discovery feature. See Section 8.2 for description.	Yes , No

Example:

```
// Master Side Connections

Connections
Port      , Protocol      , Baud      , Auto_Baud_Discovery
R2       , MBUS              , 9600     , Yes
```

5.2 Master Side Node Parameters

Section Title		
Nodes		
Column Title	Function	Legal Values
Node_Name	Provide name for Node.	Up to 32 alphanumeric characters
Protocol	Specify Protocol used.	MBUS
Node_ID	Positive integer number used to identify the Slave device.	0-250
MBus_Secondary_Address	Positive integer number used to identify the device using a secondary address.	8-digit number (e.g. 12345678)
Port	Specify which port the device is connected to the FieldServer.	R2, R1
MBus_Mode	Mode 1 is recommended for new devices. Mode 2 is for legacy devices.	1-2
MBus_SND_NKE*	"Open connection" telegram is sent before each poll when set to "Yes".	Yes, No, -
MBus_FCB_Toggle*	FCB-bit is toggled when set to "Yes".	Yes, No, -
MBus_FCB_Inverted*	Inverts FCB-bit when set to "Yes".	Yes, No, -
MBus_IM_Delay*	Inter-message delay value can be changed.	100-2000
MBus_IM_Timeout*	Inter-message timeout value can be changed.	200-2000

Example

```
// Client Side Nodes

Nodes
Node_Name , Protocol , Port , MBus_Mode , Node_ID
METER_1 , MBUS , R2 , 1 , 6
```

5.3 Master Side Map Descriptor Parameters

5.3.1 FieldServer Specific Map Descriptor Parameters

Column Title	Function	Legal Values
Map_Descriptor_Name	Name of this Map Descriptor.	Up to 32 alphanumeric characters
Data_Array_Name	Name of Data Array where data is to be stored in the FieldServer.	One of the Data Array names from Section 4
Data_Array_Offset	Starting location in Data Array.	0 to (Data_Array_Length-1) as specified in Section 4
Function	Function of Master Map Descriptor.	Rdbc, ARS
Length	Number of Data Objects.	Size of data to be read
Scan_Interval	Interval between readings.	3 -

5.3.2 All data Request Driver Related Map Descriptor Parameters

Column Title	Function	Legal Values
Node_Name	Name of Node to fetch data from.	One of the Node names specified in Section 5.2
MBus_Data_Class	Class 1 – Alarm, Class 2 – Data.	Class-1, Class-2
Linked_Map_Descriptor	If a Group address should be linked to a polling map descriptors data array.	One of the Map descriptor names specified in Section 5.3.1

5.3.3 Specific Data Request Driver Related Map Descriptor Parameters

Column Title	Function	Legal Values
Node_Name	Name of Node to fetch data from.	One of the Node names specified in Section 5.2
MBus_Data_Type	Data type.	See Section 8.1
Object_Instance	Data Offset.	1-100
MBus_Data_Format	Override the data format of data received. If not sure what to select, please leave the option blank with “-” as the default data type will be used, as given by the node.	-, NO_DATA, UINT8, UINT16, UINT24, UINT32, REAL32, UINT48, UINT64, READOUT_SELECTION, BCD2, BCD4, BCD6, BCD8, VARIABLE, BCD12, SPECIAL, FLOAT
MBus_Scaling*	If the default scaling of the Slave device must be enabled/disabled.	Yes, No
MBus_Use_Tariff_Number*	The Master uses the device’s tariff number as object instance number to store the data, when enabled. The Master uses the device’s data type instance number as object instance number to store the data, when disabled. If unsure, omit the field.	Yes, No

5.4 Map Descriptor Examples

The QuickServer is configured to be a Master and read a Slave energy meter configured as node_id = 6. The QuickServer polls the meter with the Poller, and the response message is linked to the M-Bus data types. The default data format of the meter must be used. The polling frequency has to be 0.1 Hz.

```
// Master Side Map Descriptors
// Polling Map Descriptor
Map_Descriptors
Map_Descriptor_Name , Data_Array_Name , Data_Array_Offset , Function , Node_Name , Length , Scan_Interval , MBus_Data_Class
MBUS_METER_1 , DA_POLLER , 00 , RDBC , METER_1 , 1000 , 10s , Class-2
```

Example comments:

- Function – RDBC is the most common function for MBUS Masters, as it will request the values from the node at the given interval.

```
// Linked map descriptor example, any store to a linked map descriptor will update the specified M-Bus data type.
Map_Descriptors
Map_Descriptor_Name , Data_Array_Name , Data_Array_Offset , Function , Node_Name , MBus_Data_Type
Energy_Tariff , DA_MBUS1 , 00 , Passive_Client , METER_1 , Energy_Tariff
Voltage , DA_MBUS1 , 01 , Passive_Client , METER_1 , Voltage
```

Object_Instance	MBus_Data_Class	MBus_Data_Format
1	Class-2	-
1	Class-2	-

Example comments:

- Map_Descriptor_Name – Map descriptor Energy_Tariff extracts the first instance of Energy in Watt Hour value from the MBUS_METER_1 node, using a linked map descriptor.
- Data_Array_Name – Both map descriptors use the same data array (DA_MBUS1), but reference the data at different offsets.
- Function – The function should be “Passive_Client” as the poller map descriptor already receives the data, and the linked map descriptor only needs to extract the correct data.
- Node_Name – The node name used to poll for the data must be used to link these map descriptors to the poller map descriptor.
- MBus_Data_Type – The data point type must be available in the Server device’s message. The valid data types are available in **Section 8.1**.
- Length – The data length is always 1.
- MBus_Data_Class – The M-Bus Data Class must be given (Class-1 for Alarm data, and Class-2 for other data).

6 Slave Side Configuration

For detailed information on FieldServer configuration, please refer to the FieldServer Configuration Manual. The information that follows describes how to expand upon the factory defaults provided in the configuration files included with the FieldServer (see “.csv” sample files provided with the FieldServer).

This section documents and describes the parameters necessary for configuring the FieldServer as an M-Bus Slave to respond to an M-Bus Master.

The configuration file tells the FieldServer about its interfaces, and the routing of data required. In order to enable the FieldServer for M-Bus communications, the driver independent FieldServer buffers need to be declared in the “Data Arrays” section, the destination device addresses need to be declared in the “Master Side Nodes” section, and the data required from the Slaves needs to be mapped in the “Master Side Map Descriptors” section. Details on how to do this can be found below.

NOTE: In the tables below, * indicates an optional parameter, with the bold legal value as default.

6.1 Slave Side Connection Parameters

Section Title		
Connections		
Column Title	Function	Legal Values
Port	Specify which port the device is connected to the FieldServer.	R2,1
Protocol	Specify protocol used.	MBUS
Baud*	Desired Baud rate to use for all the M-Bus Slave nodes.	300, 600, 1200, 2400 , 4800, 9600, 19200, 38400

Example

```
// Slave Side Connection

Connections
Port      , Protocol      , Baud
R2       , MBUS         , 9600
```

6.2 Slave Side Node Parameters

Section Title		
Nodes ¹		
Column Title	Function	Legal Values
Node_Name	Provide name for Node.	Up to 32 alphanumeric characters
Protocol	Specify Protocol used.	MBUS
Node_ID	Positive integer number used to identify the device.	0-250
MBus_Secondary_Address	Positive integer number used to identify the device using a secondary address.	8-digit number (e.g. 12345678)
Port	Specify which port the device is connected to the FieldServer.	R2, R1
MBus_Mode	Mode 1 is recommended for new devices, although Mode 2 support older M-Bus devices, which uses the old M-Bus instruction set.	1-2
MBus_Multiple_Poll*	The slave will respond with multiple messages only when the Master requests each message as a separate request.	Yes, No, -

Example

```
// Slave Side Nodes

Nodes
Node_Name      , Protocol      , Port      , MBus_Mode   , Node_Id     , MBus_Secondary_Address
MBus_Meter_1   , MBUS          , R2        , 1           , 7           , 12345678
```

¹ Port is not declared in the Server Side Nodes.

6.3 Server Side Map Descriptor Parameters

6.3.1 FieldServer Specific Map Descriptor Parameters

Column Title	Function	Legal Values
Map_Descriptor_Name	Name of this Map Descriptor.	Up to 32 alphanumeric characters ²
Data_Array_Name	Name of Data Array where data is to be stored in the FieldServer.	One of the Data Array names from Section 4
Data_Array_Offset	Starting location in Data Array.	0 to (Data_Array_Length-1) as specified in Section 4
Function	Function of Slave Map Descriptor.	Server
Length	Number of Data Objects.	1

6.3.2 Driver Related Map Descriptor Parameters

Column Title	Function	Legal Values
Node_Name	Name of Node to make the data available on M-Bus.	One of the Node names specified in Section 5.2
MBus_Data_Class	Class 1 – Alarm, Class 2 – Data.	Class-1, Class-2

6.3.3 Specific Data Request Driver Related Map Descriptor Parameters

Column Title	Function	Legal Values
Node_Name	Name of Node to fetch data from.	One of the Node names specified in Section 6.3.1
MBus_Data_Type	Data type.	As per Section 8.1
Object_Instance	Data Offset.	0-1000

² Object_Name values of any length may be written via BACnet (subject only to memory and message length constraints).

6.4 Map Descriptor Example

The QuickServer is configured to be an M-Bus Slave device and have two temperature values available to the Master on M-Bus address 7.

```
// Slave Side Map Descriptors
// These map descriptors will be available to the M-Bus Master at the Slave M-Bus address.
Map_Descriptors
Map_Descriptor_Name , Data_Array_Name , Data_Array_Offset , Function , Node_Name , MBus_Data_Type , Object_Instance , Length , MBus_Data_Class
Meter_1_Temp_Ext , DA_MBUS , 00 , Server , TEMP_METER , Temp_External , 1 , 1 , Class-2
Meter_1_Temp_Flow , DA_MBUS , 01 , Server , TEMP_METER , Temp_Flow , 1 , 1 , Class-2
```

Example comments:

- Map_Descriptor_Name – Map descriptor name to describe the M-Bus value.
- Data_Array_Name – Both map descriptors use the same data array (DA_MBUS), but reference the data at different offsets.
- Function – “Server” is the function for MBUS Slaves, as it will only respond to reads from the Master.
- Node_Name – The Node name defined must be used to link the map descriptor to the M-Bus address.
- MBus_Data_Type – The associated M-Bus data offset for the map descriptor is specified in this field.
- Length – The data length is always 1.
- MBus_Data_Class – The M-Bus Data Class must be given (Class-1 for Alarm data, and Class-2 for other data).

7 Troubleshooting

7.1 Driver Error Messages

Error #	Msg Screen	Screen message	Meaning	Suggested Solution
1	ERROR	DRV->MBUS: #1 Not enough space to store %u items in da %s	Data array too short.	Increase data array length to store the specified length of data elements.
2	ERROR	DRV->MBUS: #2 Out of memory	FieldServer ran out of memory.	Too many data points used, reduce configuration size.
3	DRIVER	DRV->MBUS: #3 The Slave does not support message type	Informational message to notify the message was processed, but not supported. When the FieldServer is defined as a slave device and will provide this message when a master tries read its EEPROM data.	No action required.
4	DRIVER	DRV->MBUS: #4 The Master requests node %u to use %u baud	The slave default baud is changed to the desired baud rate by the master. Information message to indicate the master's current action.	No action required.
5	DRIVER	DRV->MBUS: #5 Node %u baud rate fixed to %u baud	Informational message to indicate that the master failed to change the baud rate. When the slave default baud is fixed and cannot be changed to the master.	The master will still communicate to the slave in its fixed buad rate, therefore no action is required.
6	DRIVER	DRV->MBUS: #6 Node %u Online, AutoBaudDiscovery Off	Informational message to indicate the master found a node and is turning the Auto_Baud_Discovery off. This feature is enabled by the connection parameter Auto_Baud_Discovery specified as "Yes".	This feature is enabled by the connection parameter Auto_Baud_Discovery specified as "Yes". No further action required.
7	DRIVER	DRV->MBUS: #7 Node %u Offline, AutoBaudDiscovery On	Informational message to indicate the master doesn't get a response from the node and is turning the Auto_Baud_Discovery on. This feature is enabled by the connection parameter Auto_Baud_Discovery specified as "Yes".	This feature is enabled by the connection parameter Auto_Baud_Discovery specified as "Yes". No further action required.
8	DRIVER	DRV->MBUS: #8 Offline Node %u didn't respond on %u baud	Informational message to indicate the node did not respond to the master using the specified baud rate.	No further action as the Auto_Baud_Discovery feature will search for a node on other baud rates automatically. The connection parameter Auto_Baud_Discovery specified as "Yes" enables this feature.

Additional Information

9	DRIVER	DRV->MBUS: #9 The Master searches for node %u on %u baud	Informational message printed when Auto_Baud_Discovery is enabled, showing the current baud rate the master is using to discover a node.	No further action after the feature is enabled by the connection parameter Auto_Baud_Discovery specified as "Yes".
10	DRIVER	DRV->MBUS: #10 The Master baud rate %u is undefined	Occurs when a master is asked to request a slave to change its baud rate to an undefined value. Neither the master nor the slave will accept the request, and baud rate will default to 2400 baud.	The baud rate on the MBUS connection should be set to one of the following baud rates: 300, 600, 1200, 2400, 4800, 9600, 19200, 38400.
11	DRIVER	DRV->MBUS: #11 Unsupported MBUS data array element size, cannot get DIF %u	Unsupported data format, the data will not get stored for the specific data record.	Contact support if the specific record's value is required.
12	DRIVER	DRV->MBUS: #12 Unsupported MBUS data type, cannot get DIFE	Unsupported DIFE, the DIFE will be ignored.	Contact support if the specific record's DIFE is required.
13	DRIVER	DRV->MBUS: #13 Unsupported VIF in Slave Message %d %x - vif record	Unsupported VIF in the slave response.	The data will be available under Mbus_Data_Type "Unknown".
14	DRIVER	DRV->MBUS: #14 Unsupported MBUS data type, cannot get VIFE	Unsupported VIFE, the VIFE will be ignored.	Contact support if the specific record's VIFE is required.
15	DRIVER	DRV->MBUS: #15 Corrupted Slave Message	The slave response contains an error. This is not expected to happen too often, only with noise on the physical layer.	Check the physical MBUS connection.
16	DRIVER	DRV->MBUS: #16 Warning - MBUS packet not standard length	Information message to indicate the slave response packet length differs from the protocol standard. The response will still be processed.	No action required, if all the data is processed correctly.
20	DRIVER	DRV->MBUS: #20 Unsupported MBUS data array element format %d	Unsupported data format, the data will not get stored for the specific data record.	Contact support if the specific record's value is required.
18	DRIVER	DRV->MBUS: #18 The Slave now uses the new baud rate of %u baud	Informational message to indicate the new baud rate. This is the case where the FieldServer is defined as a slave device, and a master changed the baud rate.	No action is required.
19	DRIVER	DRV->MBUS: #19 Undefined Slave baud rate %u requested	Informational message to indicate the new baud rate. This is the case where the FieldServer is defined as a slave device, and a master changed the baud rate.	The slave ignores the request and continues to use its current baud rate. No action is required.

7.2 Short Circuit LED

Check the red LED circled below to see if a short circuit (or bus overload) has occurred on the M-Bus port.

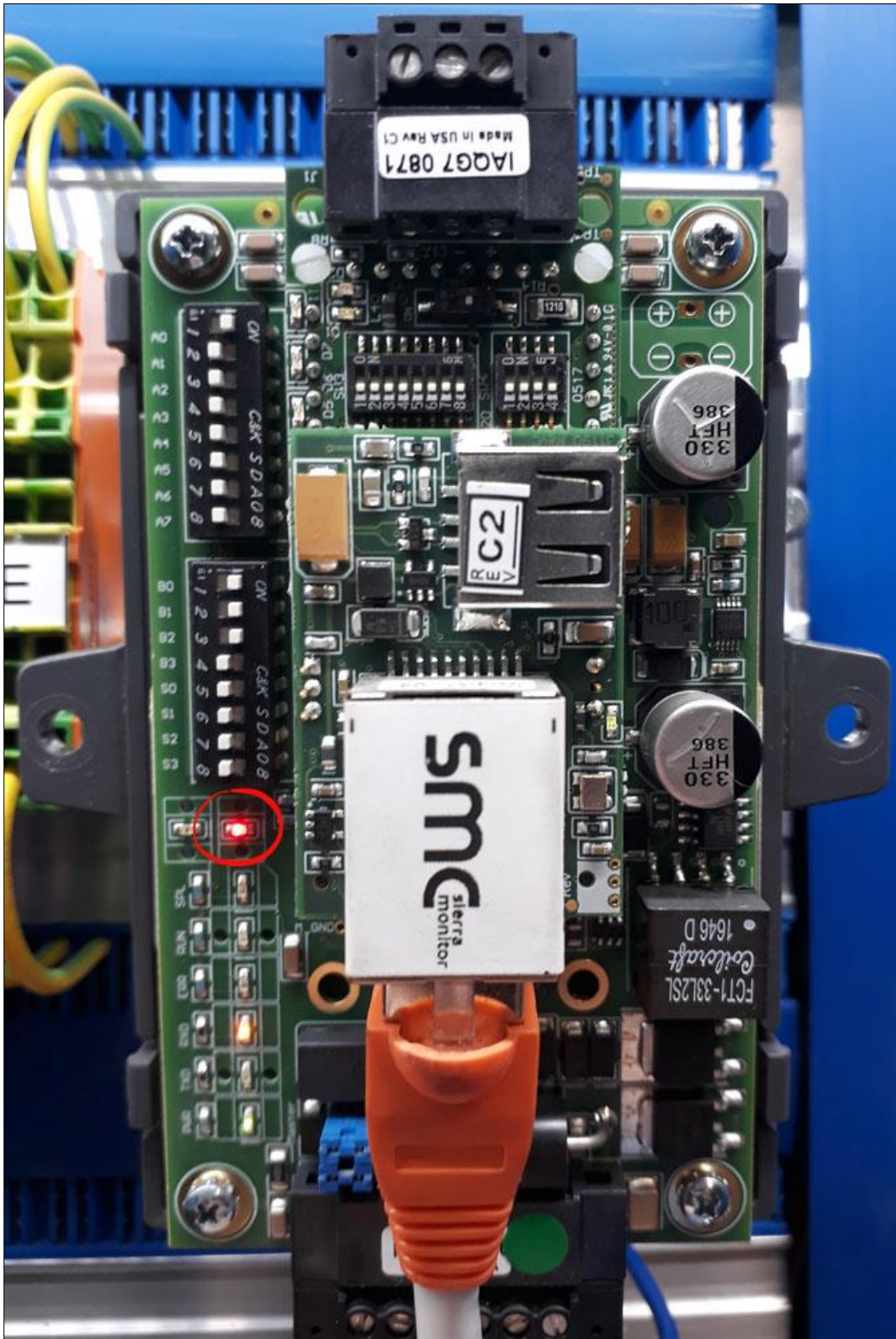

8 Reference

8.1 M-Bus Data Types

Data Type Name	Data Type Description	Recommended Data Array Value
Duration_Averaged_Sec	Averaged duration timer value seconds	FLOAT
Duration_Averaged_Min	Averaged duration timer value minutes	FLOAT
Duration_Averaged_Hrs	Averaged duration timer value hours	FLOAT
Duration_Averaged_Days	Averaged duration timer value days	FLOAT
Duration_Actual_Sec	Actual duration timer value seconds	FLOAT
Duration_Actual_Min	Actual duration timer value minutes	FLOAT
Duration_Actual_Hrs	Actual duration timer value hours	FLOAT
Duration_Actual_Days	Actual duration timer value days	FLOAT
Energy_Wh	Energy tariff in Watt Hour	FLOAT
Energy_KWh	Energy tariff in Kilo Watt Hour (Auto scaling from Wh)	FLOAT
Energy_MWh	Energy tariff in Mega Watt Hour (Auto scaling from Wh)	FLOAT
Energy_GWh	Energy tariff in Giga Watt Hour (Auto scaling from Wh)	FLOAT
Energy_J	Energy tariff in Joules	FLOAT
Energy_KJ	Energy tariff in Kilo Joules (Auto scaling from J)	FLOAT
Energy_MJ	Energy tariff in Mega Joules (Auto scaling from J)	FLOAT
Energy_GJ	Energy tariff in Giga Joules (Auto scaling from J)	FLOAT
Volume	Volume reading	FLOAT
Voltage	Voltage reading	FLOAT
Current	Current reading	FLOAT
Temp_External	External temperature reading (°C or °F)	FLOAT
Temp_Flow	Flow temperature reading (°C or °F)	FLOAT
Temp_Return	Return temperature reading (°C or °F)	FLOAT
Temp_Difference	Temperature difference reading (°C or °F)	FLOAT
Time_Sec	Current time seconds	FLOAT
Time_Min	Current time minutes	FLOAT
Time_Hrs	Current time hours	FLOAT
Time_Days	Current time days	FLOAT
Time_Operating_Sec	Time since start up seconds	FLOAT
Time_Operating_Min	Time since start up minutes	FLOAT
Time_Operating_Hrs	Time since start up hours	FLOAT
Time_Operating_Days	Time since start up days	FLOAT
Custom	Custom value, where the data type is specified in the VIF	FLOAT
Power_W	Power reading in Watts	FLOAT
Power_Jh	Power reading in Joules per hour	FLOAT
Pressure	Pressure reading in bar	FLOAT
Mass	Mass scaled value (kg)	FLOAT
Mass_Flow	Mass flow scaled value (kg/h)	FLOAT
Volume_Flow_L_M	Volume flow value in litre per minute	FLOAT
Volume_Flow_L_H	Volume flow value in litre per hour	FLOAT
Volume_Flow_L_S	Volume flow value in litre per second	FLOAT
Volume_Flow_ML_S	Volume flow value in millilitre per second	FLOAT
Alarm_Flags	Alarm flags according to device Class -1 data	BYTE
Device_ID	Device ID/ Serial Number	UINT32
Medium	Device's measuring medium	BYTE
Unknown	Unknown data type (use this to reach unsupported data types)	FLOAT

8.2 Auto Baud Discovery

The FieldServer configured as an M-Bus Master device has the ability to change each Slave to a desired standard M-Bus baud rate automatically. The FieldServer configured as an M-Bus Slave device has the ability to change its own baud to a desired standard M-Bus baud rate if requested by the Master.

Most M-Bus devices are set to start up at 2400 Baud, although some older devices have 300 Baud as their default Baud rate. The Auto Baud Discovery feature cycles through all the baud rates, and sets the device's baud rate to the desired baud rate (as specified in the connection parameter section), as soon as it finds each device's default baud rate, individually.

The Auto Baud Discovery tool automatically tries to establish a connection to the Slave device using the desired baud rate specified. If the node is offline, the tool tries to discover the node using automated search and sends a request to the device to change to the desired baud rate.

NOTE: Most M-Bus devices only support up to 9600 baud. Make sure that the device connected to the FieldServer supports the desired baud rate.

8.3 Device Profile Listings

Device Profiles
Aquametro_Calec_ST
Comet_XRM-50
Elvaco_CMa20
EMU_3PH_Power_3-85
Kamstrup_601
Kamstrup_602
Sontay_Zenner_Multidata
Sontex_SuperCal_531
Siemens_WFH21
Siemens_FUE950_Energy
QS_All_Data_Profile
Kamstrup_66
Amtron_Sonic_D
Shenitech_STUF-280T
SensusHRI-B1-8Profile

Device Profiles
KromSchroderTRZ2S1
KromSchroderDE10R25-40B
RelayPadPulsM1
AILA_AUF200
Siemens_WFN21
Siemens_UH50
Siemens_T230
Kamstrup_Multical
Siemens_UH50_Combined
Sensostar_2C
Axis_SKU-03
ECS_Elec_Mtr
Diehl_Hydrus
Diehl_Sharky_775
Metz_T_M4

8.4 VIF Table

The M-Bus protocol uses "VIFs" to indicate the unit (data type). The table below lists the possible "VIFs":

Coding	Description	Range Coding	Range
E000 0nnn	Energy	$10^{(nnn-3)}$ Wh	0.001Wh to 10000Wh
E000 1nnn	Energy	$10^{(nnn)}$ J	0.001kJ to 10000kJ
E001 0nnn	Volume	$10^{(nnn-6)}$ m ³	0.001l to 10000l
E001 1nnn	Mass	$10^{(nnn-3)}$ kg	0.001kg to 10000kg
E010 00nn	On Time	nn = 00 seconds nn = 00 seconds nn = 00 seconds nn = 00 seconds	
E010 01nn	Operating Time	Coded like OnTime	
E010 1nnn	Power	$10^{(nnn-3)}$ W	0.001W to 10000W
E011 0nnn	Power	$10^{(nnn)}$ J/H	0.001kJ/h to 10000kJ/h
E011 1nnn	Volume Flow	$10^{(nnn-6)}$ m ³ /h	0.001l/h to 10000l/h
E100 0nnn	Volume Flow Ext.	$10^{(nnn-7)}$ m ³ /min	0.001l/min to 10000l/min
E100 1nnn	Volume Flow Ext.	$10^{(nnn-9)}$ m ³ /s	0.001ml/s to 10000ml/s
E101 0nnn	Mass Flow	$10^{(nnn-3)}$ kg/h	0.001kg/h to 10000kg/h
E101 10nn	Flow Temperature	$10^{(nn-3)}$ °C	0.001°C to 1°C
E101 11nn	Return Temperature	$10^{(nn-3)}$ °C	0.001°C to 1°C
E110 00nn	Temperature Difference	$10^{(nn-3)}$ K	1mK to 100mK
E110 01nn	External Temperature	$10^{(nn-3)}$ °C	0.001°C to 1°C
E110 10nn	Pressure	$10^{(nn-3)}$ bar	1mbar to 1000mbar
E110 110n	Time Point	n = 0 date n = 1 time & date	data type G data type F
E110 1110	Units for H.C.A.		dimensionless
E110 1111	Reserved		
E111 00nn	Averaging Duration	Coded like OnTime	
E111 01nn	Actuality Duration	Coded like OnTime	
E111 1000	Fabrication No		
E111 1001	(Enhanced) Identification		
E111 1010	Bus Address		data type C (x=8)