

Driver Manual

FS-8700-138 DNP 3.0 Serial

APPLICABILITY & EFFECTIVITY

Effective for all systems manufactured after May 2025.



Driver Revision: 1.05
Document Revision: 3.D



fieldserver

MSA Safety
1000 Cranberry Woods Drive
Cranberry Township, PA 16066 USA
Website: www.MSAsafety.com

U.S. Support Information:
+1 408 964-4443
+1 800 727-4377
Email: smc-support@msasafety.com

EMEA Support Information:
+31 33 808 0590
Email: smc-support.emea@msasafety.com

Contents

1	Description	4
2	Driver Scope of Supply	5
2.1	Provided by the Supplier of 3 rd Party Equipment	5
2.1.1	Required 3 rd Party Configuration.....	5
3	Hardware Connections	6
4	Data Array Parameters	7
5	Client Side Configuration	8
5.1	Client Side Connection Parameters	8
5.2	Client Side Node Parameters	9
5.3	Client Side Map Descriptor Parameters	10
5.3.1	FieldServer Specific Map Descriptor Parameters	10
5.3.2	Driver Related Map Descriptor Parameters	10
5.3.3	Timing Parameters	11
5.4	Map Descriptor Example – General	12
5.4.1	Binary Output (DNP3Group 10)	12
5.4.2	Binary Input (DNP3Group 1)	12
5.4.3	Analog Input (DNP3Group 30)	12
5.4.4	Analog Output (DNP3Group 40)	13
5.4.5	Counter (DNP3Group 20)	13
5.4.6	Frozen Counter (DNP3Group 21)	13
5.5	Map Descriptor Example – Command Analog Output (DNP3Group 41)	14
5.6	Map Descriptor Example – Command Binary Output (DNP3 Group 12)	15
5.6.1	Command Binary Output – Generic	15
5.6.2	Command Binary Output supporting Latch Model	15
5.7	Map Descriptor Example – Freeze Counters	16
6	Server Side Configuration	17
6.1	Server Side Connection Parameters	17
6.2	Server Side Node Parameters.....	18
6.3	Server Side Map Descriptor Parameters.....	19
6.3.1	FieldServer Specific Map Descriptor Parameters	19
6.3.2	Driver Related Map Descriptor Parameters	19
6.4	Map Descriptor Examples	21
6.4.1	Binary Output Commands.....	21
6.4.2	Binary Output Command in Latch Model (DNP3Group 10).....	21
6.4.3	Binary Output Command in Activation Model (DNP3Group 10)	22
7	Useful Features	23
7.1	Map Descriptor Example – Device Attribute Read	23
7.2	Map Descriptor Example – Event Read	24
7.2.1	Binary Input Event – DNP3Group 2	24
7.2.2	Analog Input Event – DNP3Group 32	25
7.2.3	Counter Event – DNP3Group 22.....	25
7.3	Map Descriptor Example – Class Data Read.....	26
7.4	Map Descriptor Example – Cold Restart Server	26
8	Reference	27
8.1	Legal Values for FieldServer as a Master	27
8.2	Legal Values for FieldServer as a Remote Outstation	28
8.3	Driver Messages.....	30
8.3.1	Informational Messages	30
8.3.2	Error Messages	31

1 Description

The DNP 3.0 Serial driver allows the FieldServer to transfer data to and from devices over RS-232 or RS-485 using DNP 3.0 protocol. The FieldServer can emulate either a Server or Client. When the FieldServer is a Server (slave), only one Client (master) can communicate to it. The DNP 3.0 Serial Driver adheres to and supports the framework specified by the IEEE 1815-2012 Standard for electrical power system communications.

The following information was copied from the DNP 3.0 User Group Internet site:

The development of DNP3 was a comprehensive effort to achieve open, standards-based Interoperability between substation computers, RTUs, IEDs (Intelligent Electronic Devices) and master stations (except inter-master station communications) for the electric utility industry. Also important was the time frame; the need for a solution to meet today's requirements. As ambitious an undertaking as this was, we reached this objective. And since the inception of DNP, the protocol has also become widely utilized in adjacent industries such as water / waste water, transportation and the oil and gas industry.

DNP3 is based on the standards of the International Electrotechnical Commission (IEC) Technical Committee 57, Working Group 03 who have been working on an OSI 3 layer "Enhanced Performance Architecture" (EPA) protocol standard for telecontrol applications. DNP3 has been designed to be as close to compliant as possible to the standards as they existed at time of development with the addition of functionality not identified in Europe but needed for current and future North American applications (e.g. limited transport layer functions to support 2K block transfers for IEDs, RF and fiber support). DNP3 has been selected as a Recommended Practice by the IEEE C.2 Task Force; RTU to IED Communications Protocol.

DNP3 is an open and public protocol. In order to ensure interoperability, longevity and upgradeability of, protocol the DNP3 Users Group has taken ownership of the protocol and assumes responsibility for its evolution. The DNP3 Users Group Technical Committee evaluates suggested modifications or additions to the protocol and then amends the protocol description as directed by the Users Group members.

DNP3 Features:

DNP3 offers flexibility and functionality that go far beyond conventional communications protocols. Among its robust and flexible features DNP3 includes:

- *Output options*
- *Secure configuration/file transfers*
- *Addressing for over 65,000 devices on a single link*
- *Time synchronization and time-stamped events*
- *Broadcast messages*
- *Data link and application layer confirmation*

DNP3 was originally designed based on three layers of the OSI seven-layer model: application layer, data link layer and physical layer. The application layer is object-based with objects provided for most generic data formats. The data link layer provides for several methods of retrieving data such as polling for classes and object variations. The physical layer defines most commonly a simple RS-232 or RS-485 interface.

DNP3 is very efficient for a layered protocol while ensuring high data integrity

DNP3 Benefits:

Because DNP3 is based on the IEC 870-5 requirements, DNP3 is suitable for application in the entire SCADA environment. This includes RTU to IED communications, master to remote communications, and even peer-to-peer instances and network applications.

Being an object-based application layer protocol, DNP3 has the flexibility to support multiple operating modes such as poll-response, polled report-by-exception, unsolicited responses and peer-to-peer. It permits multiple masters and encourages distributed intelligence.

Users can expect many benefits from using DNP3. In the short term:

- Interoperability between multi-vendor devices
- Fewer protocols to support in the field
- Reduced software costs
- No protocol translators needed
- Shorter delivery schedules
- Less testing, maintenance and training
- Improved documentation
- Independent conformance testing
- Support by independent users group and third-party sources (e.g. test sets, source code)

Max Nodes Supported

FieldServer Mode	Nodes	Comments
Client	1-65519	The FieldServer as a client can communicate to multiple Servers (Outstations).
Server (Outstation)	1	The FieldServer can emulate as 1 single Server (Outstation) per port.

2 Driver Scope of Supply

2.1 Provided by the Supplier of 3rd Party Equipment

2.1.1 Required 3rd Party Configuration

Configure the device to use DNP 3.0 protocol on the port connected to the FieldServer.

3 Hardware Connections

The FieldServer is connected to the DNP 3.0 Serial Device as shown in the connection drawing.

Configure the DNP 3.0 Serial device according to manufacturer's instructions for RS-485 or RS-232.

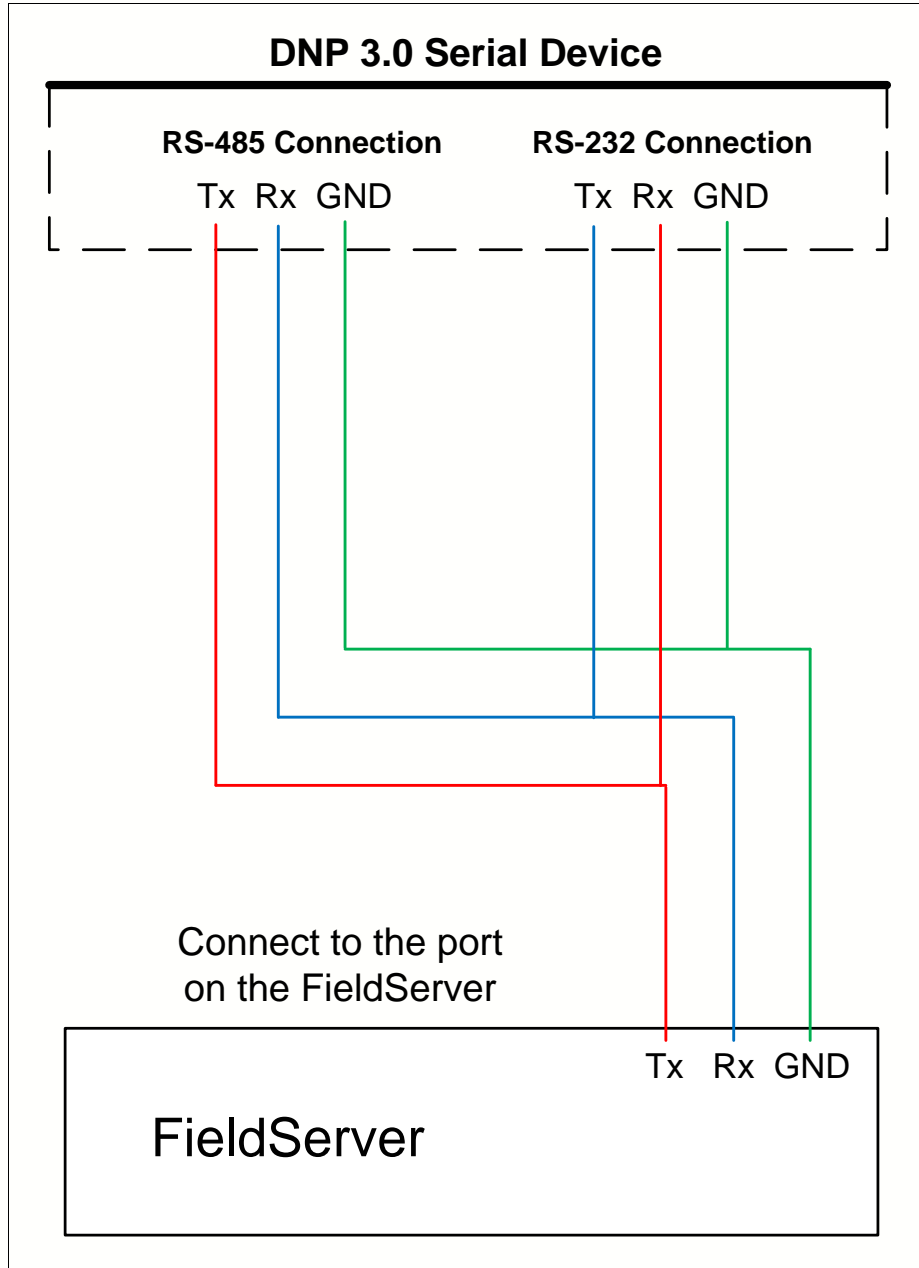

4 Data Array Parameters

Data Arrays are “protocol neutral” data buffers for storage of data to be passed between protocols. It is necessary to declare the data format of each of the Data Arrays to facilitate correct storage of the relevant data.

Section Title		
Data_Arrays		
Column Title	Function	Legal Values
Data_Array_Name	Provide name for Data Array.	Up to 15 alphanumeric characters
Data_Array_Format	Provide data format. Each Data Array can only take on one format.	Float, Bit, Byte, Uint16, Uint32, Sint16, Sint32
Data_Array_Length	Number of Data Objects. Must be larger than the data storage area required by the Map Descriptors for the data being placed in this array.	1-10000

Example

```
// Data Arrays
Data_Arrays
Data_Array_Name , Data_Array_Format , Data_Array_Length
DA_BO , Bit , 50
DA_BI , Bit , 50
DA_AI , Sint32 , 50
DA_AOS , Sint16 , 50
DA_CNT , Uint32 , 50
DA_BO_Status , Byte , 50
DA_BI_Status , Byte , 50
DA_AI_Status , Byte , 50
DA_AO_Status , Byte , 50
DA_CNT_Status , Byte , 50
DA_CNTF_Status , Byte , 50
DA_Crob_Parms , Uint32 , 200
DA_Softver , Byte , 8
DA_Hardver , Byte , 80
DA_Userid , Byte , 80
DA_Serial , Byte , 80
DA_Prodname , Byte , 80
DA_Manufname , Byte , 80
DA_Allattrib , Byte , 80
DA_Listattrib , Byte , 80
DA_BI_E_TIME , Byte , 300
```

5 Client Side Configuration

For detailed information on FieldServer configuration, refer to the FieldServer Configuration Manual. The information that follows describes how to expand upon the factory defaults provided in the configuration files included with the FieldServer (see “.csv” sample files provided with the FieldServer).

This section documents and describes the parameters necessary for configuring the FieldServer as Client (Master) to communicate with a DNP 3.0 Serial Server (Remote Outstation).

The configuration file tells the FieldServer about its interfaces, and the routing of data required. In order to enable the FieldServer for DNP 3.0 Serial communications, the driver independent FieldServer buffers need to be declared in the “Data Arrays” section, the destination device addresses need to be declared in the “Client Side Nodes” section, and the data required from the servers needs to be mapped in the “Client Side Map Descriptors” section. Details on how to do this can be found below.

NOTE: In the tables below, * indicates an optional parameter and bold legal values are default.

5.1 Client Side Connection Parameters

Section Title		
Connections		
Column Title	Function	Legal Values
Port	Specify which port the device is connected to the FieldServer.	P1-P2, R1-R2 ¹
Protocol	Specify protocol used.	Dnp3Ser, DNP3_Ser
Baud*	Specify baud rate.	300, 600, 1200, 2400, 4800, 9600 , 19200, 38400, 76800, 115200
Parity*	Specify parity.	None , Even, Odd
Data_Bits*	Specify data bits.	8 , 7
Stop_Bits*	Specify stop bits.	1 , 2
Poll_Delay*	Time between internal polls.	0- 65.535s, 0.050s
DNP3_Master_Address*	Specify Master data link address.	0 – 65519
DNP3_Broadcast_Address*	Specify the Broadcast destination address. The driver uses this as the destination address when sending the following commands. <ul style="list-style-type: none"> • Direct operate no ack (0x06) • Freeze and no ack (0x08) • Freeze, clear and no ack (0x0A) 	65533 , 65534, 65535
DNP3_UTC_Correction*	Specify the correction required to set the time to UTC time. Ensure that the local time is set on the FieldServer (using FS-GUI).	0 -2147483648 to 2147483647 (ms)
DNP3_Generate_Profile*	Specify if it is required to generate DNP 3.0 xml profile file from FieldServer configuration file.	NO , YES

Example

```
// Client Side Connections
Connections
Port , Protocol , Baud , Parity , DNP3_Master_Address , Poll_Delay
P1 , Dnp3Ser , 9600 , None , 100 , 0
```

¹ Not all ports shown are necessarily supported by the hardware. Consult the appropriate Instruction manual for details of the ports available on specific hardware.

5.2 Client Side Node Parameters

Section Title		
Nodes		
Column Title	Function	Legal Values
Node_Name	Provide name for Node.	Up to 32 alphanumeric characters
Node_ID	Specify Remote Server's (Outstation's) data link address.	0 - 65519
Protocol	Specify Protocol used.	Dnp3Ser, Dnp3_Ser
Connection	Specify through which port the device is connected to the FieldServer.	P1-P2, R1-R2 ²
DNP3_Level*	Specify DNP 3.0 level.	1, 2, 3 or 4
DNP3_Enable_Unsolicited*	Specify if Unsolicited responses are enabled on the Server (Outstation) ³	OFF, ON or NO, YES
DNP3_DII_Confirm*	Specify if CONFIRM DATA function should be used. DNP 3.0 devices mostly use UNCONFIRMED DATA function i.e. send request or response without verifying the state of the other device, but some legacy devices may require the use of the CONFIRM DATA function.	NO, YES
DNP3_DII_Retries*	Specify the number of retries to verify the communication state of the other device. This parameter will be used only if DNP3_DLL_Confirm is in use.	0 - 255
DNP3_Self_Address_Support*	Specify whether the remote Server (outstation) supports the Self Address feature. If supported, the data link address of the Server can be detected. The Driver will print the Server's data link address and then disable this feature in both devices and update the configuration file to use the known data link address under the Node_ID parameter.	NO, YES
DNP3_User_Id_Code*	Specify the user id code to be written to the Server (outstation).	Any text string up to 199 characters. Default is the 'title' of the FieldServer in the configuration file.

Example

```
// Client Side Nodes
Nodes
Node_Name , Node_ID, , Protocol , Connection , DNP3_Level
Node_A , 4 , Dnp3Ser , P1 , 2
```

² Not all ports shown are necessarily supported by the hardware. Consult the appropriate Instruction manual for details of the ports available on specific hardware.

³ This parameter should not have a value of 'ON' or 'YES' if connection is R1 or R2 (RS485).

5.3 Client Side Map Descriptor Parameters

5.3.1 FieldServer Specific Map Descriptor Parameters

Column Title	Function	Legal Values
Map_Descriptor_Name	Name of this Map Descriptor.	Up to 32 alphanumeric characters
Data_Array_Name	Name of Data Array where data is to be stored in the FieldServer.	One of the Data Array names from Section 4
Data_Array_Offset	Starting location in Data Array.	0 to (Data_Array_Length -1) as specified in Section 4
Function	Function of Client Map Descriptor.	Rdbc, Wrbc, Wrbcx, Passive

5.3.2 Driver Related Map Descriptor Parameters

Column Title	Function	Legal Values
Node_Name	Name of Node to fetch data from.	One of the Node names specified in Section 5.2
Length	Length of Map Descriptor. (The number of object instances).	1,2,3, etc.
Address	Specify object's index number.	0, 1, 2, etc.
DNP3Group*	Specify DNP 3.0 Group number. This is a numeric representation of the Object Data Type. Refer to Section 8.1 .	0 , (refer to Section 8.1)
DNP3Variation*	Specify format or additional information relevant to DNP3Group.	0 , (refer to Section 8.1)
DNP3Function*	Specify function as read, write, operate etc. 1 read 2 write 3, 4 select & operate 5 direct operate 6 direct operate and no ack 7 Freeze 8 Freeze no ack 9 Freeze clear 10 Freeze, clear and no ack 13 cold restart	Refer to Section 8.1 for default values and all options
DNP3Qualifier*	Specify the way driver encodes object index and length in DNP3 request. For example, 0 start-stop; driver will encode the range (address to address+length-1) as start and stop address and it will use 1 byte to encode start and 1 byte to encode stop. 0 (start-stop 1 byte each) 1 (start-stop 2 bytes each) 6 (no range or all) 7 (limited quantity, 1 byte indicates length) 8 (limited quantity, 2 bytes indicate length) 23 (each index encoded - use 1 byte) 40 (each index encoded - use 2 bytes)	Refer to Section 8.1 for default values and all options.

DA_Float_Name*	DNP3 Event timestamp represents the number of milliseconds since 1 Jan 1970. If Data_Array_Format of data array is UINT32, driver will use 2 offsets to store time stamp: The first offset will indicate number of seconds and next offset will represent number of milliseconds. If data format is not UINT32, driver will use 6 locations to store raw bytes for time stamp.	-, One of the Data Array names from Section 4
DA_Byte_Name*	Specify the name of the Data Array where a point's status should be stored in the FieldServer.	-, One of the Data Array names from Section 4
DNP3ControlCommand*	Specify the control command that will be generated when the Data Array is updated to value 1.	-, Not used, control command will be generated using the generic way (ontime, offtime, number of cycles), Latch On, Cancel Previous Then Latch On, Latch Off, Cancel Previous Then Latch Off

5.3.3 Timing Parameters

Column Title	Function	Legal Values
Scan_Interval*	Rate at which data is polled.	≥0.001s

5.4 Map Descriptor Example – General

5.4.1 Binary Output (DNP3Group 10)

Map_Descriptors												
Map_Descriptor_Name	Scan_Interval	Data_Array_Name	Data_Array_Offset	Function	Node_Name	DNP3Group	Address	Length	DA_Byte_Name			
ReadBO1	,5s	,DA_BO	,0	,Rdbc	,Node_A	,10	,0	,25	,DA_BO_Status			

Example comments:

- Scan_Interval – All binary outputs will be read every 5 seconds.
- Data_Array_Name – Binary output value will be stored here.
- Length – Only index 0-24 will be stored. If more binary outputs exist at the Server, increase length or add additional passive map descriptors.
- DA_Byte_Name – Status flags will be stored here.

5.4.2 Binary Input (DNP3Group 1)

Events read by the Master or sent by the Server in unsolicited responses will also be stored by this map descriptor.

Map_Descriptors												
Map_Descriptor_Name	Scan_Interval	Data_Array_Name	Data_Array_Offset	Function	Node_Name	DNP3Group	Address	Length	DA_Float_Name	DA_Byte_Name		
ReadBI1	,5s	,DA_BI	,0	,Rdbc	,Node_A	,1	,0	,25	,DA_BI_E_Time	,DA_BI_Status		

Example comments:

- Scan_Interval – All binary inputs will be read every 5 seconds.
- Data_Array_Name – Binary input value will be stored here.
- Length – Only index 0-24 will be stored. If more binary inputs exist at the Server, increase length or add additional passive map descriptors.
- DA_Float_Name – Event time will be stored here if provided by Server.
- DA_Byte_Name – Status flags will be stored here.

5.4.3 Analog Input (DNP3Group 30)

Events read by the Master or sent by the Server in unsolicited responses will also be stored by this map descriptor.

Map_Descriptors												
Map_Descriptor_Name	Scan_Interval	Data_Array_Name	Data_Array_Offset	Function	Node_Name	DNP3Group	Address	Length	DA_Byte_Name			
ReadAI1	,5s	,DA_AI	,0	,Rdbc	,Node_A	,30	,0	,25	,DA_AI_Status			

Example comments:

- Scan_Interval – All analog inputs will be read every 5 seconds.
- Data_Array_Name – Analog input value will be stored here.
- Length – Only index 0-24 will be stored. If more analog inputs exist at the Server, increase length or add additional passive map descriptors.
- DA_Byte_Name – Status flags will be stored here.

5.4.4 Analog Output (DNP3Group 40)

Map_Descriptors										
Map_Descriptor_Name	Scan_Interval	Data_Array_Name	Data_Array_Offset	Function	Node_Name	DNP3Group	Address	Length	DA_Byte_Name	
ReadAOS1	,5s	,DA_AOS	,0	,Rdbc	,Node_A	,40	,0	,25	,DA_AO_Status	

Example comments:

- Scan_Interval – All analog outputs will be read every 5 seconds.
- Data_Array_Name – Analog output value will be stored here.
- Length – Only index 0-24 will be stored. If more analog outputs exist at the Server, increase length or add additional passive map descriptors.
- DA_Byte_Name – Status flags will be stored here.

5.4.5 Counter (DNP3Group 20)

Map_Descriptors										
Map_Descriptor_Name	Scan_Interval	Data_Array_Name	Data_Array_Offset	Function	Node_Name	DNP3Group	Address	Length	DA_Byte_Name	
ReadCNT1	,5s	,DA_CNT1	,0	,Rdbc	,Node_A	,20	,0	,25	,DA_CNT_Status	

Example comments:

- Scan_Interval – All counters will be read every 5 seconds.
- Data_Array_Name – Counter value will be stored here.
- Length – Only index 0-24 will be stored. If more counters exist at the Server, increase length or add additional passive map descriptors.
- DA_Byte_Name – Status flags will be stored here.

5.4.6 Frozen Counter (DNP3Group 21)

Map_Descriptors										
Map_Descriptor_Name	Scan_Interval	Data_Array_Name	Data_Array_Offset	Function	Node_Name	DNP3Group	Address	Length	DA_Byte_Name	
ReadCNT1	,5s	,DA_CNT_F	,0	,Rdbc	,Node_A	,21	,0	,25	,DA_CNTF_Status	

Example comments:

- Data_Array_Name – Frozen counter value will be stored here.
- Length – Only index 0-24 will be stored. If more counters exist at the Server, increase length or add additional passive map descriptors.
- DA_Byte_Name – Status flags will be stored here.

5.5 Map Descriptor Example – Command Analog Output (DNP3Group 41)

The following Map Descriptors are used to command Analog Outputs. There are 3 ways an Analog Output can be commanded in DNP3:

- Direct Operate: DNP3Function 5 or unspecified will send the operate command directly and will wait for Ack from Server.
- Direct Operate no ack: DNP3Function 6 driver will send the operate command and not wait for Ack from Server.
- Select and Operate: DNP3Function 3 driver will send a command to select the particular object index on the Server. Once the Server Ack's the command, the driver will issue an operate command to actually operate the point.

The Driver will read and store the new Analog Output Status to Map Descriptors of DNP3Group 40.

Map_Descriptor_Name	Data_Array_Name	Data_Array_Offset	Function	Node_Name	DNP3Group	Address	Length	DNP3Function
MD_CAO_AO1	, DA_CAO	, 1	, Wr bx	, Node_A	, 41	, 1	, 1	, -
MD_CAO_AO2	, DA_CAO	, 2	, Wr bx	, Node_A	, 41	, 2	, 1	, 6
MD_CAO_AO3	, DA_CAO	, 3	, Wr bx	, Node_A	, 41	, 3	, 1	, 3

5.6 Map Descriptor Example – Command Binary Output (DNP3 Group 12)

5.6.1 Command Binary Output – Generic

The following Map Descriptors are used to command Binary Outputs. There are 3 ways to command Binary Outputs in DNP3.

- Direct Operate: DNP3Function 5 or unspecified will send the operate command directly and will wait for Ack from Server.
- Direct Operate no ack: DNP3Function 6 driver will send the operate command and not wait for Ack from Server.
- Select and Operate: DNP3Function 3 driver will send a command to select the particular object index on the Server. Once the Server Ack's the command, the driver will issue an operate command to actually operate the point.

To send a Binary Output command driver needs 4 parameters:

- command at specified offset on Map Descriptor
- Number of cycles at next offset (1) in data array
- ONTIME at next offset (2)
- OFFTIME at next offset (3)

Where ONTIME is the number of milliseconds for which the Output point will be active and OFFTIME is the number of milliseconds for which the Output will be deactivated and number of cycles is the number of times this on-off cycle will be executed. The Command is the raw value to be sent which is dependent upon the type of Binary Output the Server (outstation) supports i.e. Activation model, Complementary Latch Model or Complementary two-output model. This driver is designed to send any raw value. In testing it is found that irrespective of the model of the device, Output is turned ON if the command value is 1 and OFF if the command value is 4.

The Driver reads and stores the new Binary Output to Map Descriptors of DNP3Group 10.

Map_Descriptors								
Map_Descriptor_Name	Data_Array_Name	Data_Array_Offset	Function	Node_Name	DNP3Group	Address	Length	DNP3Function
MD_CROB1	DA_CROB0	0	Wrbx	Node_A	12	1	1	-
MD_CROB2	DA_CROB1	0	Wrbx	Node_A	12	2	1	6
MD_CROB3	DA_CROB2	0	Wrbx	Node_A	12	3	1	3

5.6.2 Command Binary Output supporting Latch Model

The following example uses the Latch model to control a Binary Output. The Binary Output stays in the commanded state until a new command is issued to change the state.

Map_Descriptors									
Map_Descriptor_Name	Data_Array_Name	Data_Array_Offset	Function	Node_Name	DNP3Group	Address	Length	DNP3Function	DNP3ControlCommand
MD_CAO_AO1	DA_CAO	1	Wrbx	Node_A	10	1	1	-	Latch On
MD_CAO_AO2	DA_CAO	2	Wrbx	Node_A	10	2	1	6	Cancel Previous then Latch On

The following table indicates the DNP3 Control Commands and Data Array values to use for the different Latch conditions:

Dnp3Controlcommand	Data Array Value	Command Generated
Latch On	1	0x03 (Latch On)
Latch On	0	0x04 (Latch Off)
Latch Off	1	0x04 (Latch Off)
Latch Off	0	0x03 (Latch On)
Cancel Previous Then Latch On	1	0x23 (Cancel previous Then Latch On)
Cancel Previous Then Latch On	0	0x24 (Cancel previous Then Latch Off)
Cancel Previous Then Latch Off	1	0x24 (Cancel previous Then Latch Off)
Cancel Previous Then Latch Off	0	0x23 (Cancel previous Then Latch On)

5.7 Map Descriptor Example – Freeze Counters

The following Map Descriptor will issue the command to freeze counter objects. Whenever the value at the specified offset is updated, the driver will trigger this Map Descriptor. Refer to the description of the DNP3Function for counters in **Section 5.3.2**.

Map_Descriptors							
Map_Descriptor_Name	Data_Array_Name	Data_Array_Offset	Function	Node_Name	DNP3Group	Length	DNP3Function
FreezeCNT1	DA_CNT_FR	0	Wrbc	Node_A	20	1	7

DNP3Function	Actions
7 Freeze	Server will copy the counter values to the frozen counters.
8 Freeze no ack	As 7 but Server will not send a response to the Client.
9 Freeze clear	Server will copy the counter values to the frozen counters and clear the counters.
10 Freeze, clear and no ack	As 10 but Server will not send a response to the Client.

The following Map Descriptor will issue the command to freeze counter objects every 50s.

Descriptors								
Map_Descriptor_Name	Data_Array_Name	Data_Array_Offset	Function	Node_Name	DNP3Group	Length	DNP3Function	Scan_Interval
FreezeCNT1	DA_CNT_FR	0	Wrbc	Node_A	20	1	7	50s

6 Server Side Configuration

For detailed information on FieldServer configuration, refer to the FieldServer Configuration Manual. The information that follows describes how to expand upon the factory defaults provided in the configuration files included with the FieldServer (see “.csv” files provided with the FieldServer).

This section documents and describes the parameters necessary for configuring the FieldServer to communicate with a DNP 3.0 Serial Client (Master).

The configuration file tells the FieldServer about its interfaces, and the routing of data required. In order to enable the FieldServer for DNP 3.0 Serial communications, the driver independent FieldServer buffers need to be declared in the “Data Arrays” section, the FieldServer virtual node(s) needs to be declared in the “Server Side Nodes” section, and the data to be provided to the client needs to be mapped in the “Server Side Map Descriptors” section. Details on how to do this can be found below.

NOTE: In the tables below, * indicates an optional parameter, with the bold legal value as default.

6.1 Server Side Connection Parameters

Section Title		
Connections		
Column Title	Function	Legal Values
Baud*	Specify baud rate.	300, 600, 1200, 2400, 4800, 9600 , 19200, 38400, 76800, 115200
Parity*	Specify parity.	None , Even, Odd
Data_Bits*	Specify data bits.	8 , 7
Stop_Bits*	Specify stop bits.	1 , 2
Server_Hold_Timeout*	Specifies time FieldServer will reserve the Server side connection while waiting for the Client side to update data in the Data_Array.	>1.0s, 5s
DNP3_Master_Address*	Specify Remote Master’s data link address. If unspecified, the driver will default to 0, but will dynamically update it as soon it gets any message from the Master. If specified, and it gets a different Master address in a message, the driver will print the message with Master’s data link address, and then update the configuration file.	0 – 65519
Protocol	Specify protocol used.	Dnp3Ser, DNP3_Ser
DNP3_Generate_Profile*	Specify if it is required to generate DNP3 xml profile file from FieldServer configuration file.	NO , YES

Example

```
// Server Side Connections
Connections
Port , Protocol , Baud , Parity DNP3_Master_Address
P1 , Dnp3Ser , 9600 , None , -
```

6.2 Server Side Node Parameters

Section Title		
Nodes		
Column Title	Function	Legal Values
Node_Name	Provide name for Node.	Up to 32 alphanumeric characters
Node_ID	This Server's (Outstation's) data link address.	0 - 65519
Protocol	Specify Protocol used.	Dnp3Ser, Dnp3_Ser
Port	Specify at which port the device is connected to the FieldServer.	P1-P2, R1-R2 ⁴
Timeout*	Specify timeout in seconds. This timeout is used for various timeouts. For example, confirmation timeout, 'select' timeout etc.	0-65.534, 2
DNP3_Level*	Specify DNP 3.0 level.	1, 2 , 3 or 4
DNP3_Enable_Unsolicited*	Specify if unsolicited responses are enabled or not. ⁵	OFF , ON or NO, YES
DNP3_Unsol_Retries*	Specify the number of times the driver should retransmit unsolicited responses if it does not get confirmation from Master. 4294967295 is considered infinite.	0 - 4294967295
DNP3_DII_Confirm*	Specify if CONFIRM DATA function should be used or not. DNP 3.0 devices mostly use UNCONFIRMED DATA function i.e. send request or response without verifying the state of the other device, but some legacy devices may require the use of the CONFIRM DATA function.	NO , YES
DNP3_DII_Retries*	Number of retries to verify the communication state of the other device. This parameter will be used only if DNP3_DII_Confirm is in use.	0 - 255
DNP3_User_Id_Code*	Specify the custom user id code text.	Any text string up to 199 characters. Default is 'title' of FieldServer in configuration file.
DNP3_Max_Events*	Event queue length. This is the maximum, number of unconfirmed events that driver can keep in queue. If the master remains unable to confirm the events, the new events will be discarded. The driver will keep the Bit set in every response from the Master to indicate event queue overflow.	0 – 65535, 50

⁴ Not all ports shown are necessarily supported by the hardware. Consult the appropriate Instruction manual for details of the ports available on specific hardware.

⁵ This parameter should not have a value of 'ON' or 'YES' if connection is R1 or R2 (RS485).

Configuring the FieldServer

DNP3_Self_Address_Support*	Enable/disable Self Address support feature. This feature is normally used to discover the data link address of the Server (outstation) if it is unknown during installation and the Outstation supports this feature. This is redundant in explicitly configurable FieldServers because the correct data link address (Node_ID) is required in the configuration file to enable/disable this feature.	NO, YES
DNP3_Time_Sync_Expire*	Specify the time in minutes after which the driver will set the 'Need Time' bit to indicate to the Master to set the time at the Server (outstation).	2-28800, 60 (minutes)
DNP3_MX_Fragment_Size*	Specify the maximum number of bytes of application layer to be used for a single fragment response.	2-2048
DNP3_Need_Time_Synch*	Specify if Server should set/unset 'Need Time Synch' internal indication. By default, FieldServer will request time synchronization from Client. If this parameter is 'NO' FieldServer won't request time synchronization from Client.	YES, -, NO

Example

```
// Server Side Nodes

Nodes
Node_Name , Node_ID , Protocol , Port , DNP3_Level , DNP3_Enable_Unsolicited , Timeout
Node_A , 10 , Dnp3Ser , P1 , 2 , Yes , 5s
```

6.3 Server Side Map Descriptor Parameters

6.3.1 FieldServer Specific Map Descriptor Parameters

Column Title	Function	Legal Values
Map_Descriptor_Name	Name of this Map Descriptor.	Up to 32 alphanumeric characters
Data_Array_Name	Name of Data Array where data is to be stored in the FieldServer.	One of the Data Array names from Section 4
Data_Array_Offset	Starting location in Data Array.	0 to maximum as specified in Section 4
Function	Function of Server Map Descriptor.	Passive

6.3.2 Driver Related Map Descriptor Parameters

Column Title	Function	Legal Values
Node_Name	Name of Node to fetch data from.	One of the Node Names specified in Section 6.2
Length	Length of Map Descriptor (Number of object instances).	1,2,3, etc.
Address	Specify object's index number.	0, 1, 2, etc.
DNP3Group*	Specify DNP3 Group number (numeric data type object).	0, (Section 8.2)
DNP3Variation*	Specify format of DNP3GROUP.	0, (Section 8.2)

Configuring the FieldServer

Column Title	Function	Legal Values
DNP3Qualifier*	Specify the way driver could encode object index and length in DNP3 request. For example, 0 start-stop; driver will encode the range (address to address+length-1) as start and stop address and it will use 1 byte to encode start and 1 byte to encode stop.	Refer to Section 8.2 for default values and all options
DNP3DataClass*	Specify the data class of the object: 0 – Static data (current value), no events will be generated for this data. 1, 2, 3 – Event classes, events generated for this data. 255 – Class None. When class0 data is requested, driver will provide static data from class0, class1, class2 and class3. There isn't any special consideration or priority for various event classes like Class1, class2 or class3, but normally applications assign Binary Input as class1, Analog Input as class2 and Counter as class3 data.	0, 1, 2, 3, 255
DNP3EventVariation*	Similar to DNP3Variation, but applicable only for Event objects. Default event variation will be used when sending events in unsolicited response or when the parameter is not specified.	See Section 8.2 for default values and all options
DNP3EventQualifier*	Similar to DNP3Qualifier but apply only to Event objects.	
Event_Deadband*	Specify the deadband. If value changes in this band, event will not be generated. This is applicable to Analog Input and Counter objects.	0, -2147483648 to 2147483647
DA_Float_Name*	Specify the name of the Data Array to configure the FieldServer to accept commands on Binary Output objects.	-, One of the Data Array names from Section 4
DNP3TimeDA*	Used to store the event time reported from the remote device. If this parameter is not defined, the FieldServer calculates the event time as per its own clock. To override the default event time, specify the name of a Data Array to hold the event time.	One of the Data Array names from Section 4
DNP3StatusDA*	Used to store status flags for the objects from the remote device. If this parameter is not defined, the FieldServer uses the status of the data array objects. To override the default status, specify the name of a Data Array which holds the objects status.	One of the Data Array names from Section 4
DNP3ControlModel*	Specify control model that Binary Output support. In latch model the server latches the output on or off and keep it in this state until the next command. Ontime, offtime and number of cycles are not used to change the output. In activation model the output is kept on for ontime and off for offtime for a certain number of cycles as specified in the command from the external client.	Activation, Latch (if DA_Float_Name is defined, default control model will be "Activation" otherwise "Latch")

6.4 Map Descriptor Examples

The following Map Descriptors will serve 50 objects having index 0-49 as Binary Inputs (DNP3Group 1), Analog Input (DNP3Group 30), Analog Output (DNP3Group41), Counter (DNP3Group 20) and Frozen Counter (DNP3Group 21) implicitly below Counter objects.

Map_Descriptors	Map_Descriptor_Name	Data_Array_Name	Data_Array_Offset	Function	Node_Name	DNP3Group	Address	Length	DNP3DataClass
SMD_BI1	, DA_BI	, 0	, Passive	, Node_A	, 1	, 0	, 50	, 1	
SMD_AI1	, DA_AI	, 0	, Passive	, Node_A	, 30	, 0	, 50	, 2	
SMD_AOS1	, DA_AOS	, 0	, Passive	, Node_A	, 40	, 0	, 50	, 0	
SMD_CNT1	, DA_CNT	, 0	, Passive	, Node_A	, 20	, 0	, 30	, 3	

Example comments:

- Data_Array_Name – Data Array declared in **Section 4**, data will be served to these data arrays and for analog commands new analog values will be updated in DA_AOS.
- Data_Array_Offset – Specified Data array offset holds data in data array for the specified address (object index).
- Node_Name – Node Name as declared in **Section 6.2**.
- DNP3Group – Specify the type of the object:
 - 1- Binary Input
 - 30- Analog Input
 - 40- Analog Output
 - 20- Counter
- Address – Specify the starting number of object index.
- Length – Specify the number of objects of specified type (DNP3Group).
- DNP3DataClass – Assign data class. Event will be generated for class 1, 2 and 3.

6.4.1 Binary Output Commands

Output will be turned ON (i.e. value 1 will be stored) if command is one of the following:

- 0x03 (Latch On)
- 0x23 (Cancel Previous then Latch On)
- 0x41 (Close Pulse On)
- 0x61 (Cancel Previous then Close Pulse On)

Output will be turned OFF (i.e. value 0 will be stored) if command is one of the following:

- 0x04 (Latch Off)
- 0x24 (Cancel Previous then Latch Off)
- 0x81 (Trip Pulse On)
- 0xA1 (Cancel Previous then TripPulse On)

6.4.2 Binary Output Command in Latch Model (DNP3Group 10)

The following Map Descriptors will serve 50 objects having index 0-49 as Binary Output (DNP3Group 10).

The Driver implements the latch model for all Binary Outputs.

The Driver will keep Binary Output ON or OFF until the next command.

Map_Descriptors	Map_Descriptor_Name	Data_Array_Name	Data_Array_Offset	Function	Node_Name	DNP3Group	Address	Length
SMD_BO1	, DA_BO	, 0	, Passive	, Node_A	, 10	, 0	, 50	

6.4.3 Binary Output Command in Activation Model (DNP3Group 10)

The following Map Descriptors will serve 50 objects having index 0-49 as Binary Output (DNP3Group 10), but here another parameter DA_Float_Name is required to reference another Data Array for Binary Outputs to accept commands.

The length of DA_CROB_PARDS should be 4 times the length i.e. in this case this data array length should be at least 200. The Driver uses DA_CROB_PARDS internally to compute when to turn Binary Output ON or OFF. The Driver implements the activation model for all Binary Outputs.

The Driver will keep Binary Output ON for ONTIME and OFF for OFFTIME for number of specified cycles in the command.

Map_Descriptors								
Map_Descriptor_Name	Data_Array_Name	Data_Array_Offset	Function	Node_Name	DNP3Group	Address	Length	DA_Float_Name
SMD_BO1	DA_BO	0	Passive	Node_A	10	0	50	DA_CROB_PARDS

7 Useful Features

7.1 Map Descriptor Example – Device Attribute Read

The following set of Map Descriptors are required to read/write Server device attributes.

Map Descriptor *AllAttrRqst* attribute 254 sends a request to read all device attributes, but nothing is stored in associated Data Array DA_ALLATTRIB because the data is parsed and will be stored on other Map Descriptors depending upon the data type (DNP3Variation). For example, software version (variation 242) will be stored in DA_SOFTVER; User ID Code (variation 246) will be stored in DA_USERID and so on.

List Map Descriptor *ListAttrVar* attribute 255 sends a request to read available attributes at the Server and their read/write nature, but not the actual values of attributes. The Attribute variation number and its read/write flag will be stored as a pair in DA_LISTATTRIB. E.g. offset 0 holds variation number and offset 1 its read/write flag, offset 2 will hold next variation number and offset 3 its read/write flag and so on.

Attribute variation 246 is optionally writable. Use the function Wrbx and update DA_USERID to write new user id code attribute 246 to Server.

To read each attribute individually, change the functions from Passive to Rdbc.

Map_Descriptors									
Map_Descriptor_Name	Scan_Interval	Data_Array_Name	Data_Array_Offset	Function	Node_Name	DNP3Group	DNP3Variation	Length	DNP3Function
ManfSoftVer	, 100s	, DA_SOFTVER	, 0	, Passive	, Node_A	, 0	, 242	, 8	, -
ManfHardVer	, 100s	, DA_HARDVER	, 0	, Passive	, Node_A	, 0	, 243	, 80	, -
UserIDcodenum	, 100s	, DA_USERID	, 0	, Wrbx	, Node_A	, 0	, 246	, 80	, 2
SerialNum	, 100s	, DA_SERIAL	, 0	, Passive	, Node_A	, 0	, 248	, 80	, -
ProdNameModel	, 100s	, DA_PRODNAME	, 0	, Passive	, Node_A	, 0	, 250	, 80	, -
ManfName	, 100s	, DA_MANUFNAME	, 0	, Passive	, Node_A	, 0	, 252	, 80	, -
AllAttrRqst	, 100s	, DA_ALLATTRIB	, 0	, Rdbc	, Node_A	, 0	, 254	, 80	, -
ListAttrVar	, 100s	, DA_LISTATTRIB	, 0	, Rdbc	, Node_A	, 0	, 255	, 80	, -

7.2 Map Descriptor Example – Event Read

7.2.1 Binary Input Event – DNP3Group 2

The Map Descriptor *Poller_BI_Events* will read all Binary Input events every 3s. (Qualifier is not specified). The Map Descriptor *Poller_BI_Events10* and *10b* will read up to 10 Binary Input events every 3s. Qualifier 7 will cause the length to be encoded in 1 byte, while Qualifier 8 will cause the length to be encoded in 2 bytes.

The response data from these requests will be stored on other Map Descriptors described with DNP3Group 1 (Binary Inputs).

Map_Descriptors								
Map_Descriptor_Name	Scan_Interval	Data_Array_Name	Data_Array_Offset	Function	Node_Name	DNP3Group	Length	DNP3Qualifier
Poller_BI_Events	, 3s	, DA_BI_E_Poller	, 0	, Rdbc	, Node_A	, 2	, 1	, -
Poller_BI_Events10	, 3s	, DA_BI_E_Poller7	, 0	, Rdbc	, Node_A	, 2	, 10	, 7
Poller_BI_Events 10b	, 3s	, DA_BI_E_Poller8	, 0	, Rdbc	, Node_A	, 2	, 10	, 8

The following Map Descriptors will read all Binary Input events for the variation specified if the qualifier is not specified or is specified as 6 every 3s. If the qualifier is specified as 7 or 8 it will request only a limited number of events as per specified length. The response data from these requests will be stored on other Map Descriptors described with DNP3Group 1 (Binary Inputs)

Variation 1 – Without Time

Variation 2 – With Absolute Time

Variation 3 – With Relative Time

Map_Descriptors									
Map_Descriptor_Name	Scan_Interval	Data_Array_Name	Data_Array_Offset	Function	Node_Name	DNP3Group	Length	DNP3Variation	DNP3Qualifier
Poller_BI_Events1	, 3s	, DA_BI_E_Poller1	, 0	, Rdbc	, Node_A	, 2	, 1	, 1	, -
Poller_BI_Events2	, 3s	, DA_BI_E_Poller2	, 0	, Rdbc	, Node_A	, 2	, 10	, 2	, 7
Poller_BI_Events3	, 3s	, DA_BI_E_Poller3	, 0	, Rdbc	, Node_A	, 2	, 10	, 3	, 8

7.2.2 Analog Input Event – DNP3Group 32

The Map Descriptor *Poller_AI_Events* will read all Analog Input events every 3s. (Qualifier is not specified). The Map Descriptors *Poller_AI_Events10* and *10b* will read up to 10 Analog Input events every 3s. Qualifier 7 will cause the length to be encoded in 1 byte, while Qualifier 8 will cause the length to be encoded in 2 bytes.

The response data from these requests will be stored on other Map Descriptors described with DNP3Group 30 (Analog Inputs)

Map_Descriptors								
Map_Descriptor_Name	Scan_Interval	Data_Array_Name	Data_Array_Offset	Function	Node_Name	DNP3Group	Length	DNP3Qualifier
Poller_AI_Events	, 3s	, DA_AI_E_Poller	, 0	, Rdbc	, Node_A	, 32	, 1	, -
Poller_AI_Events10	, 3s	, DA_AI_E_Poller7	, 0	, Rdbc	, Node_A	, 32	, 10	, 7
Poller_AI_Events 10b	, 3s	, DA_AI_E_Poller8	, 0	, Rdbc	, Node_A	, 32	, 10	, 8

7.2.3 Counter Event – DNP3Group 22

The Map Descriptor *Poller_CNT_Events* will read all Counter events every 3s. (Qualifier is not specified). The Map Descriptors *Poller_CNT_Events10* and *10b* will read up to 10 Counter events every 3s. Qualifier 7 will cause the length to be encoded in 1 byte, while Qualifier 8 will cause the length to be encoded in 2 bytes.

The response data from these requests will be stored on other Map Descriptors described with DNP3Group 20 (Counters).

Map_Descriptors								
Map_Descriptor_Name	Scan_Interval	Data_Array_Name	Data_Array_Offset	Function	Node_Name	DNP3Group	Length	DNP3Qualifier
Poller_CNT_Events	, 3s	, DA_CNT_E_Poller	, 0	, Rdbc	, Node_A	, 22	, 1	, -
Poller_CNT_Events10	, 3s	, DA_CNT_E_Poller7	, 0	, Rdbc	, Node_A	, 22	, 10	, 7
Poller_CNT_Events 10b	, 3s	, DA_CNT_E_Poller8	, 0	, Rdbc	, Node_A	, 22	, 10	, 8

7.3 Map Descriptor Example – Class Data Read

In the DNP3 Server (Outstation), almost all of the data has been assigned to 1 of the 4 classes. Class 0 holds all the static data and the other classes hold events data. Thus, the Client can read all data using the following 4 Map Descriptors. DNP3Group 60 represents class data object. Variation 1 means class0, variation 2 represents class1.

The response data will be stored on other Map Descriptors described earlier to hold data for various objects like Binary Inputs, Binary Input Events, Binary Outputs, Analog Inputs, Analog Inputs Events, Analog Outputs, Counters, Counters Events, Frozen Counters etc.

Map_Descriptors								
Map_Descriptor_Name	Scan_Interval	Data_Array_Name	Data_Array_Offset	Function	Node_Name	DNP3Group	DNP3Variation	Length
CMD_Class0_Poller	, 16s	, DA_Poller0	, 0	, Rdbc	, Node_A	, 60	, 1	, 1
CMD_Class1_Poller	, 16s	, DA_Poller1	, 0	, Rdbc	, Node_A	, 60	, 2	, 1
CMD_Class2_Poller	, 16s	, DA_Poller2	, 0	, Rdbc	, Node_A	, 60	, 3	, 1
CMD_Class3_Poller	, 16s	, DA_Poller3	, 0	, Rdbc	, Node_A	, 60	, 4	, 1

The following Map Descriptors send requests to read a limited number of events (10) for any class. Response data will be stored on other Map Descriptors described earlier.

Map_Descriptors									
Map_Descriptor_Name	Scan_Interval	Data_Array_Name	Data_Array_Offset	Function	Node_Name	DNP3Group	DNP3Variation	Length	DNP3Qualifier
CMD_Class1_Poller	, 16s	, DA_Poller1	, 0	, Rdbc	, Node_A	, 60	, 2	, 10	, 7
CMD_Class2_Poller	, 16s	, DA_Poller2	, 0	, Rdbc	, Node_A	, 60	, 3	, 10	, 8
CMD_Class3_Poller	, 16s	, DA_Poller3	, 0	, Rdbc	, Node_A	, 60	, 4	, 10	, 7

7.4 Map Descriptor Example – Cold Restart Server

The following Map Descriptor issues the command to cold restart the remote server (outstation). When the value at the specified offset is updated, the Map Descriptor is triggered.

Map_Descriptors						
Map_Descriptor_Name	Data_Array_Name	Data_Array_Offset	Function	Node_Name	DNP3Function	Length
MD_COLD_RESTART	, DA_COLDRES	, 0	, Wrbx	, Node_A	, 13	, 1

If the panel is set to the French language, the Communication parameters 19200, N81 need to be applied to the RPM Module before it will communicate to the FieldServer.

8 Reference

NOTE: In the legal value tables below, default values are indicated using bold type.

8.1 Legal Values for FieldServer as a Master

Object Data Type	DNP3 Functions	DNP3 Group	DNP3 Variation	DNP3 Qualifier
Device Attributes		0	242 (Software version) 243 (Hardware version) 246 (User assigned ID code/number) 248 (Serial number) 250 (Product name and model) 252 (Manufacturer's name) 254 (Non-specific all attribute read request) 255 (List of attribute variations) 0 (invalid)	1 for DNP3Variation 242, 243, 246, 248, 250, 252, 254, 255 2 also available for 246
Binary Input		1	0 (Any) 1 (Packed Format) 2 (With flags)	0, 1, 6
Binary Input Event		2	0 (Any) 1 (Without time) 2 (With Absolute time) 3 (With Relative time)	6 , 7, 8
Double-bit Binary Input		3	0 (Any) default 1 (Packed Format) 2 (With Flags)	6 , 0, 1
Double-bit Binary Input Event		4	0 (Any) 1 (Without time) 2 (With Absolute time) 3 (With Relative time)	6 , 7, 8
Binary Output		10	0 (Any)	6
Binary command-Control Relay Output block CROB	3, 4, 5 , 6	12	1 (Control Relay Output block CROB)	23, 40
Counter		20	0 (Any)	6
Frozen Counter		21	0 (Any)	1
Counter Event		22	0 (Any)	6 , 7, 8
Analog Input		30	0 (Any) 1 (32bit with flag) 2 (16bit with flag) 3 (32bit without flag) 4 (16bit without flag) 5 (single precision floating point with flag)	6 , 0, 1

Object Data Type	DNP3 Functions	DNP3 Group	DNP3 Variation	DNP3 Qualifier
Analog Input Event		32	0 (Any) default 1 (32bit without time) 2 (16bit without time) 3 (32bit with time) 4 (16bit with time) 5 (single precision floating point without time) 7 (single precision floating point with time)	6, 7, 8
Analog Output Status		40	0 (Any) default 1 (32bit with flag) 2 (16bit with flag) 3 (single precision floating point with flag)	6, 0, 1
Analog Output	3,4,5,6	41	1 (32bit) 2 (16bit) 3 (single precision floating point)	23, 40
Analog Output Event		42	0 (Any) default 1 (32bit without time) 2 (16bit without time) 3 (32bit with time) 4 (16bit with time) 5 (single precision floating point without time) 7 (single precision floating point with time)	6, 7, 8
Time & Date – Absolute Time		50		
Class Object		60		
Internal Indications		80		

8.2 Legal Values for FieldServer as a Remote Outstation

NOTE: All “Event” object data types utilize EventVariation and EventQualifier DNP3 parameters.

Object Data Type	DNP3 Group	DNP3 Variation or EventVariation	DNP3 Qualifier or EventQualifier
Device Attributes	0		0 (1Byte start-stop)
Binary Input	1	1 – Bit Packed 2 – Bit with flag	0 (1Byte start-stop) 1 (2Byte start-stop)
Binary Input Events	2	1 – Without Time 2 – With Absolute time 3 – With Relative time	40 – (each index will be encoded and each will use 2 bytes) 23 – (each index will be encoded and each will use 1 byte)
Double-bit Binary Input	3	1 - Packed Format 2 - With Flags	0 (1Byte start-stop) 1 (2Byte start-stop)
Double-bit Binary Input Event	4	1 – Without Time 2 – With Absolute time 3 – With Relative time	40 – (each index will be encoded and each will use 2 bytes) 23 – (each index will be encoded and each will use 1 byte)

Additional Information

Object Data Type	DNP3 Group	DNP3 Variation or EventVariation	DNP3 Qualifier or EventQualifier
Binary Output	10	2 – Output Status with flags	0 (1Byte start-stop) 1 (2Byte start-stop)
Counter Frozen Counter	20 21	1 – 32 Bit with Flag 2– 16 Bit with Flag 5– 32 Bit without flag 6– 16 Bit without flag	0 (1Byte start-stop) 1 (2Byte start-stop)
Counter Event	22	1 –32-bit for 32-bit Counter (i.e. if variation is 1 or 5) 2 –16-bit for 16-bit Counter (i.e. if variation is 2 or 6)	40 – (each index will be encoded and each will use 2 bytes) 23 – (each index will be encoded and each will use 1 byte)
Analog Input	30	1 – 32 Bit with Flag 2– 16 Bit with Flag 3– 32 Bit without flag 4– 16 Bit without flag 5 - (Single precision floating point with flag)	0 (1Byte start-stop) 1 (2Byte start-stop)
Analog Input Events	32	1 (32bit without time) (default if variation is 1 or 3) 2 (16bit without time) 3 (32bit with time) (default if variation is 2 or 4) 4 (16bit with time) 5 (single precision floating point without time) (default if variation is 5) 7 (single precision floating point with time)	40 – (each index will be encoded and each will use 2 bytes) 23 – (each index will be encoded and each will use 1 byte)
Analog Output	40	1 (32bit with flag) 2 (16bit with flag) 3 (single precision floating point with flag)	0 (1Byte start-stop) 1 (2Byte start-stop)
Analog Output Event	42	1 (32bit without time) (default if variation is 1) 2 (16bit without time) (default if variation is 2) 3 (32bit with time) 4 (16bit with time) 5 (single precision floating point without time) (default if variation is 5) 7 (single precision floating point with time)	40 – (each index will be encoded and each will use 2 bytes) 23 – (each index will be encoded and each will use 1 byte)
Time & Date CTO (Common Time Object)	51		7 (limited quantity 1 Byte)
Time Delay	52		7 (limited quantity 1 Byte)

8.3 Driver Messages

8.3.1 Informational Messages

Screen Message	Meaning	Suggested Solution
"Driver is cold restarting..."	Received Dnp3 cold restart request and dnp3 driver is resetting its state to initial state. It will also reset all dnp3 data arrays.	No action required.
"Messages from remote master (Master_Address %d) will be ignored"	Received message from unknown master.	If this is the intended master, edit configuration file and update Master_Address.
"Remote master's (Master_Address) is %d"	Master_Address is not specified in configuration file, driver is reporting master address whenever master connects to the FieldServer.	No action required.
"Remote outstation's address (Node_id) is %d"	FieldServer and remote Server (outstation) were configured to use self-address support and FieldServer found remote device's address.	Edit configuration file to update Node_Id and remove Self_Address_Support parameter.
"No need for Self_Address_Support, configured Node_id is same as outstation's Address %d"	FieldServer and remote Server (outstation) were configured to use self-address support and FieldServer found remote device's address is same as specified in configuration file.	Edit configuration file to remove Self_Address_Support parameter.
"MD<%s> length %d is too long, Not using it for class0 data response"	Data under the specified Map Descriptor will not be included in 'All Static Data' (class0) response. Master devices mostly use this request to sync data on startup.	Edit configuration and split this Map Descriptor to multiple Map Descriptors of smaller lengths.
"Too much data to fit in single fragment for class0, First MD<%s> skipped"	FieldServer has a lot more data that can fit in a fragment (2048 bytes), so data from this Map Descriptor and up to the end of Dnp3 Map Descriptors in configuration file will not be included in class0 response.	Mostly no action required because generally master uses this request only on startup. One can also have the master configured to read each group individually.
"No Md found for Node<%d> Group=%d Variation=%d"	No Map Descriptor found to store this data.	Edit configuration to add Map Descriptors to store this data.
"No Md found for Node<%d> Group=%d Address=%d"	No Map Descriptor found to store this data.	Edit configuration to add Map Descriptors to store this data.
"Deactivating BO offset=%d da=%s after %lums "	Storing value 0 at specified location for Binary output point, also indicating how long it was ON.	This is an informational message. No action required.
"Activating BO offset=%d da=%s after %lums "	Storing value 1 at specified location for Binary output point, also indicating how long it was OFF.	This is an informational message. No action required.
"Remote Device<%d> restarted"	The Remote device indicated restarted.	This is an informational message. No action required.
"Device profile document <%s> is available"	The device profile document has been created and is available for upload from the FieldServer.	This is an informational message. No action required. Optionally, document could be uploaded for review.

Additional Information

"Device variation=%d is not writable"	Received message to update device attribute but this attribute is not writable.	Re-configure remote device to avoid such requests.
"MD<%s> length should be %d"	Bigger Map Descriptor is required to store all the related data.	Edit configuration to update Map Descriptor length.
"Activating BO off=%d DA=%s at %dms"	Storing value 1 at specified location for Binary output point.	This is an informational message. No action required.
"Latching on BO off=%d DA=%s at %dms"	Storing value 1 at specified location for Binary output point.	This is an informational message. No action required.
"Latching off BO off=%d DA=%s at %dms"	Storing value 0 at specified location for Binary output point.	This is an informational message. No action required.
"Latching on close BO off=%d DA=%s at %dms"	Received 'Close Pulse On' command, so storing value 1 at specified location for Binary output point.	This is an informational message. No action required.
"Latching off trip BO off=%d DA=%s at %dms"	Received 'Trip Pulse On' command, so storing value 0 at specified location for Binary output point.	This is an informational message. No action required.
"Tx Msg Queue is full"	Due to a problem, messages are not being delivered to network and thus internal message queue is full.	Occasional messages should be ignored as the system will recover itself, but frequent occurrences should be reported to technical support.

8.3.2 Error Messages

Screen Message	Meaning	Suggested Solution
"Failed to create device profile document"	Error occurred while creating device profile document.	Report if device profile document should be created, otherwise edit configuration and remove Generate_Profile parameter.
"Write thru is not supported, Use explicit WRBX or WRBC Map Descriptors"	Data under control of a "rdbc" Map Descriptor was updated, and the Dnp3 driver does not support write-thru.	If this write is intentional edit configuration file and add wrbx or wrbc Map Descriptors, otherwise avoid updating this data.
"Error occurred while generating device profile <%s>"	Error occurred while creating device profile document.	Report if device profile document should be created, otherwise edit configuration and remove Generate_Profile parameter.
"Setting Time & Date to %d/%d/%d %d:%d:%d.%d"	Received time sync request.	This is an informational message. No action required.
"Failed to set clock"	Received time sync request but failed to update system clock.	This should be reported to technical support.